

CATALOGUE/CATÁLOGO

METAL CUTTING
CORTE METAL

GRINDING - POLISHING
LIJADORAS - ESMERILADORAS

WOOD AND ALU CUTTING
CORTE DE MADERA Y ALUMINIO

20
24



A WORLD OF PERFORMANCE



A WORLD OF PERFORMANCE

FEMI SpA is an Italian company that after fifty-seven years of history keeps unchanged the will to be a reference brand in the world of machines intended for professionals users.

Our mission is the continuous search for novelties and best solutions to design and produce innovating, safe and high-quality products. Year by year, FEMI brand has known how to renew itself by offering efficient and innovative solutions for those who want the best tool to work in a precise and safe way or even just for those who want to build with their own hands and their creativity the objects of daily life.

FEMI es una empresa italiana que, después cincuenta y siete años de historia, mantiene la voluntad de ser una marca de referencia en el mundo de las máquinas destinadas al trabajo de profesionales. Nuestra misión es la búsqueda continua de novedades y la mejor solución para diseñar y construir productos de vanguardia, seguros y de alta calidad. Con el tiempo, la marca FEMI ha sabido renovarse ofreciendo soluciones eficaces e innovadoras para aquellos que quieren lo mejor para trabajar de una manera precisa y segura aunque sea para aquellos que quieren construir su propias manos y con su creatividad los objetos de la vida cotidiana.

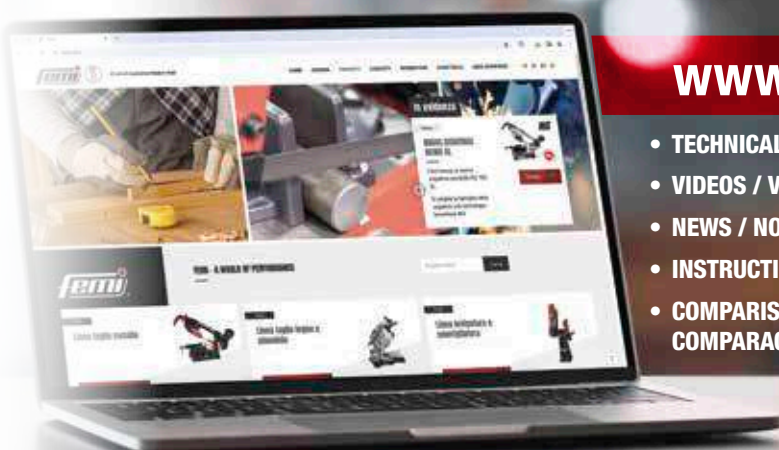

www.femi.it



- TECHNICAL DATA SHEETS / FICHAS TÉCNICAS
- VIDEOS / VIDEOS
- NEWS / NOVEDAD
- INSTRUCTION MANUALS / MANUALES DE INSTRUCCIONES
- COMPARISON OF PRODUCTS FOR THE RIGHT CHOICE / COMPARACIÓN DE PRODUCTOS PARA LA ELECCIÓN CORRECTA

METAL CUTTING LINE / LÍNEA CORTE METAL

BANDSAWS - INDUSTRIAL RANGE SIERRAS DE CINTA INDUSTRIALES	2
ACCESSORIES - INDUSTRIAL RANGE ACCESORIOS - SERIE INDUSTRIAL	16
HANGING FLEXIBLE SYSTEM EQUIPO FLEXIBLE PÉNSIL	17
BIMETAL BANDSAWS BLADES - INDUSTRIAL RANGE HOJAS DE CINTA BIMETÁLICAS - SERIE INDUSTRIAL	18
BANDSAWS PROFESSIONAL RANGE SIERRAS DE CINTA PROFESIONALES	20
ACCESSORIES - PROFESSIONAL RANGE ACCESORIOS - SERIE PROFESIONAL	38
BIMETAL BANDSAW BLADES - PROFESSIONAL RANGE HOJAS DE CINTA BIMETÁLICAS - SERIE PROFESIONAL	40

GRINDING - POLISHING LINE / LÍNEA LIJADORAS - ESMERILADORAS

BELT SANDERS - INDUSTRIAL RANGE LIJADORAS DE BANDA INDUSTRIALES	42
BENCH GRINDERS ESMERILADORAS	49
SHARPENING MACHINES AFILADORAS	57
ACCESSORIES ACCESORIOS	58
GRINDING WHEELS, BRUSHES AND BELTS MUELAS, CEPILLOS Y BANDAS	60

WOOD LINE / LINEA MADERA

MITRESAWS TRONZADORAS DE MADERA	62
CIRCULAR BLADES DISCOS	74
ACCESSORIES ACCESORIOS	76

DISPLAYS

2700 LINE / LÍNEA 2700

2600 LINE / LÍNEA 2600

THREE-PHASE WITH
AUTOMATIC DOWN FEED
AND SLIDING VICE

TRIFÁSICA CON
BAJADA AUTOMÁTICA
Y VICIO DESLIZANTE



N310DA DG

SLIDING VICE
MORDAZA DESLIZANTE



Three-phase motor with
automatic down feed.

Motor trifásica
con bajada automática.

PAG. 4

THREE-PHASE WITH
AUTOMATIC DOWN FEED

TRIFÁSICA CON
BAJADA AUTOMÁTICA



N276DA XL



Three-phase motor with
automatic down feed.

Motor trifásica
con bajada automática.

PAG. 6



VIDEO

THREE-PHASE
TRIFÁSICA

N266 XL



Three-phase motor.
Motor trifásica.

PAG. 8



SINGLE-PHASE WITH
AUTOMATIC DOWN FEED

MONOFÁSICA CON
BAJADA AUTOMÁTICA

SINGLE-PHASE
MONOFÁSICA

2500 LINE / LÍNEA 2500



N257DA DG
SLIDING VICE
MORDAZA DESLIZANTE

 253 

Three-phase motor with automatic down feed.
Motor trifásica con bajada automática.

PAG. 9

MAGNETIKO

NEW



MAGNETIC CHIP COLLECTOR
suitable for all bandsaws
VARILLA MAGNÉTICA
para todas las sierras de cinta.



N251DA XL

 250 

Three-phase motor with automatic down feed.
Motor trifásica con bajada automática.

PAG. 10

2200 LINE / LÍNEA 2200

H19-1750 LINE / LÍNEA H19-1750



N250DA XL

 250 

Single-phase motor with automatic down feed.
Motor monofásica con bajada automática.

PAG. 11



2200DA XL

 200 

Single-phase motor with automatic down feed.
Motor monofásica con bajada automática.

PAG. 12



ABS 1750 XL

 160 

Universal motor.
Motor universal.
AUTOMATIC BLADE SYSTEM

PAG. 14



2200 XL

 200 

Universal motor.
Motor universal.

PAG. 13



1750 XL

 160 

Universal motor.
Motor universal.

PAG. 15

N310_{DA} DG

AUTOMATIC DOWN FEED
BAJADA AUTOMÁTICA

ART.	CODE / CÓDIGO
N310 DA DG	8.48.90.26



SLIDING VICE
0°/60° LEFT
0°/45° RIGHT

MORDAZA DESLIZANTE
0°/60° IZQUIERDA
0°/45° DERECHA

femim

TECHNICAL FEATURES

- Powerful two speed three-phase motor with oil lubricated gear box
- Arm, vice and swivel group made in cast iron
- Side sliding vice and cut up to 45° right and up to 60° left
- Arm down feed system with hydraulic cylinder and adjustable flow
- Blade tensioning level pressure gauge
- Sliding blade guide with double ball bearings
- Electric/hydraulic front integrated panel
- Motor thermic protection and end-cut switch
- Blade cleaning brush

STANDARD EQUIPMENT

- Column in assembly kit
- Quick locking system vice
- End-cut automatic switch
- Alu frame lubrication pump
- Bar-stop rod for mass-produced cuts
- Workpiece roller support

CARACTERÍSTICAS TÉCNICAS

- Potente motor trifásico a dos velocidades con motoriductor lubricado
- Brazo, mordaza y base rotatoria en hierro fundido
- Mordaza deslizante lateral y corte hasta 45° derecha y 60° izquierda
- Sistema de bajada brazo con cilindro hidráulico y regulador de flujo
- Manómetro que indica la tensión de la hoja
- Guía-hoja deslizante en acero con doble cojinetes
- Panel de control eléctrico / hidráulico delantero integrado
- Protección térmica del motor y interruptor de fin del corte
- Cepillo limpio hoja

EQUIPAMIENTO DE SERIE

- Base en kit de montaje
- Mordaza con sistema de bloqueo rápido
- Interruptor de parada automática fin del corte
- Bomba de lubricación con cuerpo en aluminio
- Varilla regulable para cortar en serie
- Rodillo de soporte de la pieza



• Side sliding vice and cut up to 45° right and up to 60° left.
• Mordaza deslizante lateral y corte hasta 45° derecha y 60° izquierda.





• Large knob for an easy blade tensioning and pressure gauge indicating blade tensioning level.
• Perilla grande para una tensión de la hoja fácil y manómetro que indica tensión de la hoja.



• Electric/hydraulic front integrated panel for a practical and easy use.
• Panel de control eléctrico/hidráulico delantero para un uso práctico y fácil.

CUTTING CAPACITY / CAPACIDAD DE CORTE

			
0°	320x200 mm	255 mm	195 mm
45° left/izquierda	210x80 mm	205 mm	195 mm
60° left/izquierda	120x135 mm	125 mm	125 mm
45° right/derecha	170x190 mm	205 mm	175 mm



1,0/1,5 



2750x27x0.9



6/10*



35/70



110



1720x700x1540



344

*Standard bimetal cobalt blade | De serie hoja bimetálica al cobalto •  400 Volt - Hz 50 three-phase motor | Motor trifásico 400 Volt - Hz 50

N276DA XL

AUTOMATIC DOWN FEED
BAJADA AUTOMÁTICA

ART.	CODE / CÓDIGO
N276DA XL	8.48.80.71

PATENTED



VIDEO

TECHNICAL FEATURES

- Blade height 27 mm
- Hydraulic control system for automatic down feed
- Automatic or manual function
- Adjustable left cutting angle from 0° to 60° equipped with quick stop device at 45° and 60° positions
- Blade tensioner with indicator lamp and safety microswitch for proper blade integrity and tensioning

STANDARD EQUIPMENT

- Adjustable bar stop-rod for mass-produced cuts (L=600 mm)
- Steel column with built-in tool-holder
- Column in assembly kit

CARACTERÍSTICAS TÉCNICAS

- Altura hoja 27 mm
- Sistema hidráulico de control de bajada automática
- Funcionamiento automático o manual
- Ángulo de corte regulable de 0° a 60° izquierda, con dispositivo de bloqueo rápido en las posiciones 45° y 60°
- Tensor de hoja con indicador luminoso y microinterruptor de seguridad para garantizar tensado de la hoja correcto

EQUIPAMIENTO DE SERIE

- Varilla de sujeción del material regulable para realizar cortes en serie (L=600 mm)
- Base de acero, con espacio porta-objetos integrado
- Base in kit de montaje



GREAT CUTTING CAPACITY Ø 255 mm!!!
GRAN CAPACIDAD DE CORTE Ø 255 mm!!!



- Cast iron arm for a great strength (total weight 305 kg).
- Brazo de hierro fundido de gran robustez (peso total 305 kg).

CUTTING CAPACITY / CAPACIDAD DE CORTE

0°	265x200 mm	255 mm	200x200 mm
45°	200x160 mm	175 mm	170x170 mm
60°	115x100 mm	110 mm	100x100 mm



- Hydraulic control system for automatic down feed.
- Sistema hidráulico de control de bajada automática.



1,0/1,3



2565x27x0,9



8/12*



35/70



60

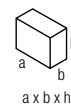

1410x870x1650



311

*Standard bimetal cobalt blade / De serie hoja bimetálica al cobalto • 400 Volt - Hz 50 three-phase motor / Motor trifásico 400 Volt - Hz 50

N266 XL

ART.	CODE / CÓDIGO
N266 XL	8.48.80.27

PATENTED

TECHNICAL FEATURES

- Blade height 27 mm
- Cast iron arm for a great strenght
- Vise with quick clamping device and non-skid jaws
- Blade tensioner with indicator lamp and safety microswitch for proper blade integrity
- Adjustable left cutting angle from 0° to 60° equipped with quick stop device at 45° and 60° positions
- Cutting angle front indicator

STANDARD EQUIPMENT

- Adjustable bar stop-rod for mass-produced cuts (L=600 mm)
- Stainless steel column with built-in tool-holder
- Column in assembly kit

CARACTERÍSTICAS TÉCNICAS

- Altura hoja 27 mm
- Brazo en hierro fundido de gran robustez
- Mordaza con bloqueo rápido y bocas antideslizantes
- Tensor de hoja con indicador luminoso y microinterruptor de seguridad para garantizar tensado de la hoja correcto
- Ángulo de corte regulable de 0° a 60°, con dispositivo de bloqueo rápido en las posiciones 45° y 60°
- Indicador frontal del ángulo de corte



EQUIPAMIENTO DE SERIE

- Varilla de sujeción del material regulable para realizar cortes en serie (L=600 mm)
- Base de acero, con espacio porta-objetos integrado
- Base in kit de montaje



THREE-PHASE TRIFÁSICA

CUTTING CAPACITY / CAPACIDAD DE CORTE

			
0°	265x200 mm	225 mm	200x200 mm
45°	200x160 mm	175 mm	170x170 mm
60°	115x100 mm	110 mm	100x100 mm



- Powerful three phase 2 speeds induction motor
- Potente motor de inducción trifásico à 2 velocidades



- Vise with quick clamping device and non-skid jaws
- Mordaza con bloqueo rápido y bocas antideslizantes (peso total 305 kg)



KILOWATT

1,0/1,3 



2565x27x0,9



8/12*



35/70



WATT

60

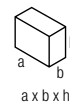

1410x870x1650



Kg

311

*Standard bimetal cobalt blade / De serie hoja bimetalica al cobalto •  400 Volt - Hz 50 three-phase motor / Motor trifásico 400 Volt - Hz 50

N257DA DG

AUTOMATIC DOWN FEED
BAJADA AUTOMÁTICA

ART.	CODE / CÓDIGO
N257DA DG	8.48.80.56

SLIDING VICE
0° / 60° LEFT
0° / 45° RIGHT

MORDAZA DESLIZANTE
0° / 60° IZQUIERDA
0° / 45° DERECHA

TECHNICAL FEATURES

- Powerful three phase 2 speeds induction motor, oil lubricated motor gearbox
- Arm, vice and swivel group in cast iron
- Steel sliding blade guide with bearings
- Vice with quick clamping device
- Lubrication pump with aluminium body
- Large knob for an easy blade tensioning
- Pressure gauge indicating blade tension level (600-1000 kg/cm²)

STANDARD EQUIPMENT

- Column in assembly kit
- Tank for lubricating oil
- Lubricating pump
- Bar stop-rod for mass-produced cuts
- Branches for adjustments, blade replacement and blade protection disassembly
- Blade cleaning brush
- Hydraulic cylinder with flow regulation

CARACTERÍSTICAS TÉCNICAS

- Potente motor de inducción trifásico a 2 velocidades con motorreductor lubricado
- Brazo, mordaza y base rotatoria en hierro fundido
- Guía-hoja deslizante en acero con cojinetes
- Mordaza con sistema de bloqueo rápido
- Bomba de lubricación con cuerpo en aluminio
- Perilla grande para una tensión de la hoja fácil
- Manómetro que indica tensión de la hoja (600-1000 kg / cm²)

EQUIPAMIENTO DE SERIE

- Base en kit de montaje
- Tanque de recogida por aceite lubricante
- Bomba de lubricación
- Varilla de sujeción para realizar cortes en serie
- Llaves para remplazar la hoja y para el desmontaje de la protección de la hoja
- Cepillo para limpiar la hoja
- Cilindro hidráulico con regulador de flujo



THREE-PHASE
TRIFÁSICA

CUTTING CAPACITY / CAPACIDAD DE CORTE

0°	245xH148- 253xH70	225 mm	180	
45° left/izquierda	90xH180	140 mm	120	
60° left/izquierda	85xH115	90 mm	90	
45° right/derecha	132xH180	148 mm	140	



- Hydraulic cylinder with flow regulation
- Cilindro hidráulico con regulador de flujo

KILOWATT	mm	Z/1"	M/min	WATT	a x b x h mm	Kg
0,75/1,1	2480x27x0,9	6/1 0*	45/90	100	1385x580x890	235

*Standard bimetal cobalt blade / De serie hoja bimetálica al cobalto • 400 Volt - Hz 50 three-phase motor / Motor trifásico 400 Volt - Hz 50

N251DA XL

AUTOMATIC DOWN FEED
BAJADA AUTOMÁTICA

ART.	CODE / CÓDIGO
N251DA XL	8.48.80.50

TECHNICAL FEATURES

- Powerful three phase 2 speeds induction motor, oil lubricated motor gearbox
- Arm, vice and swivel group in cast iron
- Steel sliding blade guide with bearings
- Vice with quick clamping device
- Frontal swivel release lever integrated in the base
- Lubrication pump with aluminium body
- Large knob for an easy blade tensioning
- Pressure gauge indicating blade tension level (600-1000 kg/cm²)

STANDARD EQUIPMENT

- Column in assembly kit
- Tank for lubricating oil
- Lubricating pump
- Bar stop-rod for mass-produced cuts
- Branches for adjustments, blade replacement and blade protection disassembly
- Blade cleaning brush
- Hydraulic cylinder with flow regulation

CARACTERÍSTICAS TÉCNICAS

- Base en kit de montaje
- Tanque de recogida por aceite lubricante
- Bomba de lubricación
- Varilla de sujeción para realizar cortes en serie
- Llaves para remplazar la hoja y para el desmontaje de la protección de la hoja
- Cepillo para limpiar la hoja
- Cilindro hidráulico con regulador de flujo

EQUIPEMENTS DE SÉRIE

- Potente motor de inducción trifásico à 2 velocidades con motorreductor lubricado
- Brazo, mordaza y base rotatoria en hierro fundido
- Guia-hoja deslizante en acero con cojinetes
- Mordaza con sistema de bloqueo rápido
- Palanca frontal de desbloqueo de la base giratoria integrada en la base
- Bomba de lubricación con cuerpo en aluminio
- Perilla grande para una tensión de la hoja fácil
- Manómetro que indica tensión de la hoja (600-1000 kg/cm²)



THREE-PHASE
TRIFÁSICA

CUTTING CAPACITY / CAPACIDAD DE CORTE

0°	L 240 x H 160 mm L 250 x H 110 mm	225 mm	185x185 mm
45°	L 135 x H 185mm L 145 x H 150 mm	150 mm	145x145 mm
60°	L 63 x H 107 L 69 x H 90	70 mm	70x70 mm



- Powerful three phase 2 speeds induction motor
- Potente motor de inducción trifásico à 2 velocidades



- Hydraulic cylinder with flow regulation
- Cilindro hidráulico con regulador de flujo



0,75/1,1



2480x27x0,9



6/10*



45/90



100

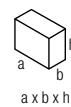

1385x580x890



200

*Standard bimetal cobalt blade / De serie hoja bimetálica al cobalto • 400 Volt - Hz 50 three-phase motor / Motor trifásico 400 Volt - Hz 50

N250DA XL

AUTOMATIC DOWN FEED
BAJADA AUTOMÁTICA

ART.	CODE / CÓDIGO
N250DA XL	8.48.80.52

TECHNICAL FEATURES

- Powerful single phase induction motor, oil lubricated motor gearbox
- Arm, vice and swivel group in cast iron
- Arm down feed system through hydraulic cylinder with flow regulation
- Steel sliding blade guide with bearings
- Vice with quick clamping device
- Frontal swivel release lever integrated in the base
- Lubrication pump with aluminium body
- Pressure gauge indicating blade tension level (600-1000 kg/cm²)

STANDARD EQUIPMENT

- Column in assembly kit
- Tank for lubricating oil
- Lubricating pump
- Bar stop-rod for mass-produced cuts
- Brenches for adjustments, blade replacement and blade protection disassembly
- Blade cleaning brush
- Hydraulic cylinder with flow regulation

CARACTERÍSTICAS TÉCNICAS

- Potente motor de inducción monofásico con motorreductor lubricado
- Brazo, mordaza y base en hierro fundido
- Sistema de bajada del brazo a través de cilindro hidráulico con regulador de flujo
- Guia-hoja deslizante en acero con cojinetes
- Mordaza con sistema de bloqueo rápido
- Palanca frontal de desbloqueo de la base giratoria integrada en la base
- Bomba de lubricación con cuerpo en aluminio
- Manómetro que indica tensión de la hoja (600-1000 kg/cm²)



EQUIPEMENTS DE SÉRIE

- Base en kit de montaje
- Tanque de recogida por aceite lubricante
- Bomba de lubricación
- Varilla de sujeción para realizar cortes en serie
- Llaves para remplazar la hoja y para el desmontaje de la protección de la hoja
- Cepillo para limpiar la hoja
- Cilindro hidráulico con regulador de flujo



SINGLE PHASE
MONOFÁSICA

CUTTING CAPACITY / CAPACIDAD DE CORTE

			
0°	L 240 x H 160 mm L 250 x H 110 mm	225 mm	185x185 mm
45°	L 135 x H 185mm L 145 x H 150 mm	150 mm	145x145 mm
60°	L 63 x H 107 L 69 x H 90	70 mm	70x70 mm



- Rear blade guide with blade cleaning brush
- Guia hoja posterior con cepillo para limpiar la hoja



- Large knob for an easy blade tensioning and pressure gauge indicating blade tensioning level
- Perilla grande para una tensión de la hoja fácil y manómetro que indica tensión de la hoja



1100 



2480x27x0,9



6/10*



72



100

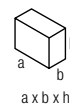

1385x580x890



200

*Standard bimetal cobalt blade / De serie hoja bimetálica al cobalto •  230 Volt - Hz 50 single-phase motor / Motor monofásico 230 Volt - Hz 50

2200 DA XL

AUTOMATIC DOWN FEED
BAJADA AUTOMÁTICA

ART.	CODE / CÓDIGO
2200DA XL	8.48.70.24

TECHNICAL FEATURES

- Hydraulic control system of arm down feed speed
- End-cut stop by micro switch system
- Blade tensioning device with light indicator and safety micro-switch to check the proper blade tension
- Powerful 2000 W universal single-phase motor equipped with digital electronic speed regulator "Constant Speed" and amperometric limiting device

STANDARD EQUIPMENT

- Integrated and protected lubricating system
- Filter-circuit for electromagnetic interference damping according to rules in force
- Column included in assembly kit

CARACTERÍSTICAS TÉCNICAS

- Sistema de control hidráulico de la velocidad de bajada
- Micro interruptor de fin carrera de corte
- Tensado de la hoja con indicador luminoso y microinterruptor de seguridad para controlar la integridad de la hoja
- Potente motor monofásico universal (2000 W) con regulación electrónica digital de velocidad "Constant Speed" con limitador amperimétrico y protección térmica



EQUIPAMIENTO DE SERIE

- Instalación de lubricación/refrigeración integrada y protegida
- Circuito-filtro para la eliminación de interferencias electromagnéticas conforme con las normativas vigentes
- Base en kit de montaje



SINGLE PHASE
MONOFÁSICA

CUTTING CAPACITY / CAPACIDAD DE CORTE

			
0°	200x75 mm 190x135 mm	175 mm	175x175 mm
45°	150x110 mm	110 mm	110x110 mm
60°	100x70 mm	75 mm	75x75 mm



- Control panel in ergonomic position for starting and adjusting the cutting operations.
- Panel de control en posición ergonómica para iniciar y ajustar las operaciones de corte.



- Closed circuit hydraulic system for arm descent control.
- Sistema hidráulico de circuito cerrado para control de la bajada del brazo.



2000 



2140x19x0,9



6/10*



35 ÷ 80

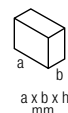

780x1240x1080



143

*Standard bimetal cobalt blade / De serie hoja bimetálica al cobalto •  230 Volt - Hz 50 single-phase motor / Motor monofásico 230 Volt - Hz 50

2200 XL

ART.	CODE / CÓDIGO
2200 XL	8.48.70.22

TECHNICAL FEATURES

- Blade tensioning device with light indicator and safety micro-switch to check the proper blade tension
- Powerful 2000 W universal single-phase motor equipped with digital electronic speed regulator "Constant Speed" and amperometric limiting device
- Cast iron quick locking vice with quick sliding system
- Front sliding saw blade guide

STANDARD EQUIPMENT

- Integrated and protected lubricating system
- Filter-circuit for electromagnetic interference damping according to rules in force
- Column included in assembly kit

CARACTERÍSTICAS TÉCNICAS



- Tensado de la hoja con indicador luminoso y microinterruptor de seguridad para controlar la integridad de la hoja
- Potente motor monofásico universal (2000 W) con regulación electrónica digital de velocidad "Constant Speed" con limitador amperimétrico y protección térmica
- Mordaza de hierro fundido de bloqueo rápido, provista de sistema de deslizamiento veloz
- Guía-hoja deslizable anterior

EQUIPAMIENTO DE SERIE

- Instalación de lubricación/refrigeración integrada y protegida
- Circuito-filtro para la eliminación de interferencias electromagnéticas conforme con las normativas vigentes
- Base en kit de montaje



CUTTING CAPACITY / CAPACIDAD DE CORTE

			
0°	200x75 mm 190x135 mm	175 mm	175x175 mm
45°	150x110 mm	110 mm	110x110 mm
60°	100x70 mm	75 mm	75x75 mm



- Cut with lubrication system max 200 mm
- Corte con lubricación max 200 mm



- Cast iron quick locking vice with quick sliding system.
- Mordaza de hierro fundido de bloqueo rápido, provista de sistema de deslizamiento veloz.



2000 



2140x19x0,9



6/10*



35 ÷ 80

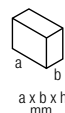

780x1240x1080



140

*Standard bimetal cobalt blade / De serie hoja bimetálica al cobalto •  230 Volt - Hz 50 single-phase motor / Motor monofásico 230 Volt - Hz 50

ABS 1750 XL



ART.	CODE / CÓDIGO
ABS 1750 XL	8.48.60.91

TECHNICAL FEATURES

- Push-Click System with mechanical selector and automatic cut-off switches
- Integrated lubricating system, easy to adjust for cutting pieces of different sizes
- Sliding rolls for supporting in- and out-going workpieces
- Safety emergency button to stop cutting
- Blade tensioning device with clutch to achieve the proper blade tension (PATENTED)
- Energy saving 100% motor efficiency is granted by the exclusive ABS System

STANDARD EQUIPMENT

- Column in assembly kit
- Removable Tank for lubricating oil
- Lubricating pump
- Bar stop-rod for mass-produced cuts
- Sliding rolls for supporting both in- and out-going workpieces

CARACTERÍSTICAS TÉCNICAS

- Push-click: 4 velocidades de corte, con selector mecánico
- Sistema integrado de lubricación, fácil a orientar para cortar piezas de diferentes tamaños
- Rodillas deslizantes por el apoyo de las piezas en entrada y salida
- Botón de seguridad para detener el corte
- Tensor de la hoja con embrague para la correcta regulación del tensado (PATENTADO)
- El exclusivo sistema ABS asegura el 100% del rendimiento del motor

EQUIPEMENTS DE SÉRIE

- Base en kit de montaje
- Bañera extraíble por aceite lubricante
- Bomba de lubricación
- Varilla de sujeción para realizar cortes en serie
- Rodillos deslizantes por el apoyo de las piezas en entrada y salida



BLADE HEIGHT
19 mm!
LAMA ALTURA
19 mm!

CUTTING CAPACITY / CAPACIDAD DE CORTE

0°	160x140 mm	155 mm	150x150 mm
45°	100x120 mm	110 mm	100x100 mm



- Blade height 19mm for a more heavy duty work
- Lama altura 19mm para un trabajo más intenso y continuo



- Powerful motor (2000 watt) to cut any kind of material
- Potente motor (2000 W) para cortar cualquier material



2000



1735x19x0,9



8/12*



35 ÷ 80

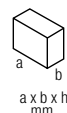

780x1240x1080



75

*Standard bimetal cobalt blade / De serie hoja bimetálica al cobalto • 230 Volt - Hz 50 single-phase motor / Motor monofásico 230 Volt - Hz 50

1750 XL

ART.	CODE / CÓDIGO
1750 XL	8.48.60.90

TECHNICAL FEATURES

- Blade height 19 mm for a more heavy duty work
- Integrated lubricating system, easy to adjust for cutting pieces of different sizes
- Sliding rolls for supporting in- and out-going workpieces
- Integrated quick sliding vice
- Blade tensioning device with clutch to achieve the proper blade tension (PATENTED)
- Double sliding saw blade guide

STANDARD EQUIPMENT

- Column in assembly kit
- Removable Tank for lubricating oil
- Lubricating pump
- Bar stop-rod for mass-produced cuts
- Sliding rolls for supporting both in- and out-going workpieces

CARACTERÍSTICAS TÉCNICAS

- Lama altura 19 mm para un trabajo más intenso y continuo
- Sistema integrado de lubricación, fácil a orientar para cortar piezas de diferentes tamaños
- Rodillos deslizantes por el apoyo de las piezas en entrada y salida
- Base con mordaza integrada y sistema de deslizamiento veloz
- Tensor de la hoja con embrague para la correcta regulación del tensado (PATENTADO)

EQUIPEMENTS DE SÉRIE

- Base en kit de montaje
- Bañera extraíble por aceite lubricante
- Bomba de lubricación
- Varilla de sujeción para realizar cortes en serie
- Rodillos deslizantes por el apoyo de las piezas en entrada y salida



BLADE HEIGHT 19 mm!
LAMA ALTURA 19 mm!

CUTTING CAPACITY / CAPACIDAD DE CORTE

0°	160x140 mm	155 mm	150x150 mm
45°	100x120 mm	110 mm	100x100 mm



- Blade height 19 mm for a more heavy duty work.
- Lama altura 19 mm para un trabajo más intenso y continuo.



- Powerful motor (2000 watt) to cut any kind of material.
- Potente motor (2000 W) para cortar cualquier material.



2000



1735x19x0,9



8/12*



35 ÷ 80



LT min 8,5

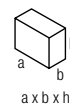

780x1240x1080



75

*Standard bimetal cobalt blade / De serie hoja bimetálica al cobalto • 230 Volt - Hz 50 single-phase motor / Motor monofásico 230 Volt - Hz 50

ROLLER STANDS / SOPORTE RODILLOS MODULARES

ART.	CODE CÓDIGO	SIZE AxBxH (mm) DIMENSIONES AxBxH (mm)	ROLLER CAPACITY CAPACIDAD DEL RODILLO	APPLICATION APLICACIÓN	FOR ART. PARA ART.
326	7.13.37.03	1000x300x880÷970	200 kg	Bars loading/unloading Carga/descarga barras	N310DA DG - N257 DADG - N276DA XL N250DA XL - N251DA XL - N266DA XL
327	7.13.37.04	1000x300x880÷970	200 kg	Supplemental module Módulo adicional	- N266XL - N265XL - N216XL - 2200XL - 2200DA XL

TECHNICAL FEATURES

- Steel rollers Ø 50 mm fitted with bearings
- Liquid collection tank made of sturdy steel sheet
- Pipe steel structure. Adjustable support feet
- Possibility to fit 8 vertical antifall rollers

CARACTERÍSTICAS TÉCNICAS

- Rodillos de acero Ø 50 mm montados sobre cojinetes
- Recipiente de recogida del líquido de robusta chapa de acero
- Estructura tubular de acero. Pies de apoyo de altura regulable
- Adaptación para 8 rodillos verticales anticaída

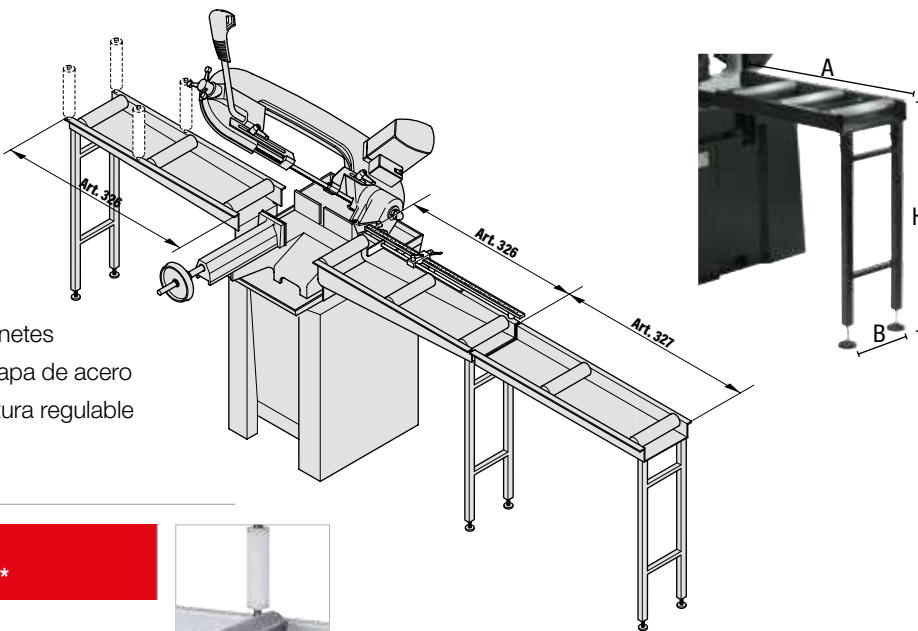

**VERTICAL ANTIFALL TEFLON ROLLER*
RODILLO VERTICAL REVESTIDO DE TEFLÓN***

CODE / CÓDIGO	SIZE (mm) / DIMENSIONES (mm)
7.21.42.11	Ø 40x150



MILLIMETRIC BAR STOP RODS* / VARILLAS DE SUJECIÓN DE LA BARRA MILLIMETRADA*

CODE / CÓDIGO	FOR ART. / PARA ART.	LENGHT / LARGO
7.13.05.76	326	1000 mm
7.13.05.77	327	1000 mm



*On request - Bajo pedido

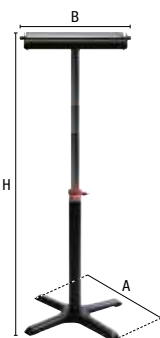

TECHNICAL FEATURES

- Zinc-plated steel roller Ø 57 mm
- Sturdy steel structure
- Base equipped with leveling feet
- Support height adjustment
- Maximum charge: 30 kg

CARACTERÍSTICAS TÉCNICAS

- Rodillo de acero galvanizado ø 57 mm
- Robusta estructura de acero, hierro fundido
- Base provista de pies de nivelación
- Regulación de la altura de apoyo
- Max posibilidad de carga: 30 kg

SINGLE-ROLLER SUPPORT | SOPORTE MONO-RODILLO

ART.	CODE CÓDIGO	SIZE AxBxH (mm) DIMENSIONES AxBxH (mm)	WEIGHT PESO
301	7.13.37.16	520x400x680÷1140	6,5 kg

NEW



TECHNICAL FEATURES

- Magnetic chip collector with ergonomic handle
- Stainless and lightweight shaft
- Ideal to reach hard areas
- To collect metal chips, nails and small metal components from chip-releasing machinery
- By extracting the central bar you can easily release the collected metal parts

CARACTERÍSTICAS TÉCNICAS

- Varilla magnética con mango ergonómico
- Eje inoxidable y liviano
- Ideal para zonas de difícil acceso
- Para recoger virutas de metal, clavos y pequeños componentes metálicos de la maquinaria liberadora de virutas.
- Extrayendo la barra central podrás liberar fácilmente las piezas metálicas recogidas

CENTRIFUGAL PUMPS / ELECTROBOMBAS CENTRÍFUGAS

ART.	CODE CÒDIGO	WATT	mm	TYPE OF PUMP USED TIPO DE BOMBA APLICADA
120	8.38.20.21	60	60	-
121	8.38.21.21	60	85	-
122	8.38.22.21	60	120	-
123	8.38.23.21	60	150	-
220	8.38.16.31	180	200	-
221	8.38.17.31	180	260	-
222	8.38.18.31	250	200	-
223	8.38.19.31	250	260	-
226	8.38.10.31	120	-	art. 228
227	8.38.07.31	120	90	-
228	8.38.08.31	120	120	-
229	8.38.09.31	120	200	-

☐ 230 Volt - Hz 50 single-phase motor - Motor monofásico 230 Volt - Hz 50

☐ 400 Volt - Hz 50 three-phase motor - Motor trifásico 400 Volt - Hz 50

The continuous service self-priming electric pumps are suitable for continuous coolant flow and assure absolute operating safety even at high temperatures.

Las electrobombas con autocebado para servicio continuo, son aptas para la circulación continua de líquidos refrigerantes, y garantizan una absoluta seguridad de funcionamiento con elevadas temperaturas.

LOADING DIAGRAMS / DIAGRAMAS DE CARGA

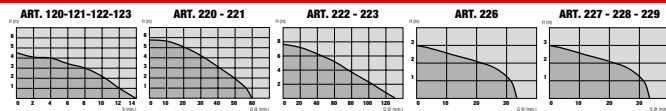

ELECTRIC PUMP DIMENSIONS / DIMENSIONES DE LAS ELECTROBOMBAS

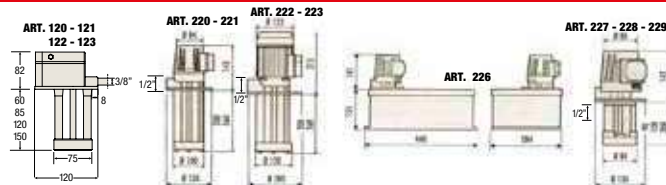

HANGING FLEXIBLE SYSTEM / EQUIPO FLEXIBLE PÉNSIL

ART.	CODE CÒDIGO	WATT	RPM	FLEXIBLE SHAFT ÀRBOL FLEXIBLE	BUNDLE PIEZA DE MANO	CHUCK MANDRIL	Kg
623	8.31.07.21	350	21000	∅ 6x14x1200	∅ 24	∅ 6	3,2

☐ 230 Volt - Hz 50 single-phase motor - Motor monofásico 230 Volt - Hz 50

TECHNICAL FEATURES

- Handy and versatile
- Electronic device for speed adjustment
- Double safety insulation

STANDARD EQUIPMENT

- Flexible shaft
- Chuck for ∅ 6mm tools
- Electronic pedal rheostat

ACCESSORIES

- Chuck ∅ 2,3 - 3 - 4 mm
- Support rod

CARACTERÍSTICAS TÉCNICAS

- Sumamente manejable y versátil
- Velocidad regulable electrónicamente
- Doble aislamiento de seguridad

EQUIPAMIENTO DE SERIE

- Arbol flexible
- Mandril para herramienta ∅ 6 mm
- Reòstato electrònico a pedal

ACCESORIOS

- Madril ∅ 2,3 - 3 - 4 mm
- Varilla de soporte



CODE
CÓDIGO



PACK
CAJA

TECHNICAL FEATURES

- Bimetal cobalt blades M42 for high cutting performance
- Suitable for dry cutting, too
- High resistance and productivity both for solid materials and for profiles
- Available in standard packs of 1 or 5 pieces

CARACTERÍSTICAS TÉCNICAS

- Hojas bimetálicas al cobalto M42 para elevadas prestaciones de corte
- Ideales también para cortes en seco
- Gran resistencia y productividad tanto en materiales macizos como en perfilados
- Disponibles en paquetes estándar de 1 ó 5 piezas

ART. N310 DA DG

2700

3.28.00.56	2750x27x0,9	6/10*	1 pc
3.28.00.60	2750x27x0,9	6/10*	5 pc
3.28.00.55	2750x27x0,9	4/6	1 pc
3.28.00.59	2750x27x0,9	4/6	5 pc
3.28.00.54	2750x27x0,9	8/12	1 pc
3.28.00.58	2750x27x0,9	8/12	5 pc
3.28.00.57	2750x27x0,9	10/14	1 pc
3.28.00.61	2750x27x0,9	10/14	5 pc

ART. N276DAXL-N266DAXL-N266XL-N265XL

2600

3.28.00.28	2565x27x0,9	8/12*	1 pc.
3.28.00.32	2565x27x0,9	8/12*	5 pc.
3.28.00.26	2565x27x0,9	4/6	1 pc.
3.28.00.30	2565x27x0,9	4/6	5 pc.
3.28.00.27	2565x27x0,9	5/8	1 pc.
3.28.00.31	2565x27x0,9	5/8	5 pc.
3.28.00.29	2565x27x0,9	10/14	1 pc.
3.28.00.33	2565x27x0,9	10/14	5 pc.

ART. N257DADG-N251DAXL-N250DAXL

2500

3.28.00.42	2480x27x0,9	6/10*	1 pc.
3.28.00.44	2480x27x0,9	6/10*	5 pc.
3.28.00.39	2480x27x0,9	4/6	1 pc.
3.28.00.41	2480x27x0,9	4/6	5 pc.
3.28.00.38	2480x27x0,9	8/12	1 pc.
3.28.00.40	2480x27x0,9	8/12	5 pc.
3.28.00.43	2480x27x0,9	10/14	1 pc.
3.28.00.45	2480x27x0,9	10/14	5 pc.

ART. 787DAXL-787XL**-2200DAXL*-2200XL*-N216XL***

2200

3.27.99.36	2140x19x0,9	6/10*	1 pc.
3.27.99.39	2140x19x0,9	6/10*	5 pc.
3.28.00.24	2140x19x0,9	8/12**	1 pc.
3.28.00.25	2140x19x0,9	8/12**	5 pc.
3.27.99.38	2140x19x0,9	4/6	1 pc.
3.27.99.41	2140x19x0,9	4/6	5 pc.
3.27.99.37	2140x19x0,9	14	1 pc.
3.27.99.40	2140x19x0,9	14	5 pc.

ART. ABS 1750XL-1750XL

H19mm - 1750

3.28.00.47	1735x19x0,9	8/12*	1 pc.
3.28.00.51	1735x19x0,9	8/12*	5 pc.
3.28.00.48	1735x19x0,9	4/6	1 pc.
3.28.00.52	1735x19x0,9	4/6	5 pc.
3.28.00.46	1735x19x0,9	6/10	1 pc.
3.28.00.50	1735x19x0,9	6/10	5 pc.
3.28.00.49	1735x19x0,9	14	1 pc.
3.28.00.53	1735x19x0,9	14	5 pc.

* Standard fitting on bandsaws / En dotación estándar en las SIERRA

CHOOSE YOUR BLADE! ¡ HELIGE TU HOYA



BI-METAL BAND SAW BLADES IN M42 HSS that combine excellent thermal resistance with high cutting speed. The particular structure of the blade allows it to resist bending, tension and pressure stresses.

HOJAS DE SIERRA DE CINTA BIMETÁLICAS EN M42 HSS que combinan una excelente resistencia térmica con una alta velocidad de corte. La estructura particular de la hoja le permite resistir tensiones de flexión, tensión y presión.



SOLID MATERIALS / MATERIALES SÓLIDOS

BLADE HOJA	ABS 1750XL - 1750XL				2200XL - 2200 DAXL				N250DA XL N251DA XL N257DA DG				N266XL - N276DA XL				N310 DA DG			
	1735x19x0,9mm				2140x19x0,9mm				2480x27x0,9mm				2565x27x0,9mm				2750x27x0,9mm			
TPI (Teeth Per Inch) Dientas para inch	Z14	Z8/12	Z6/10	Z4/6	Z14	Z8/12	Z6/10	Z4/6	Z10/14	Z8/12	Z6/10	Z4/6	Z10/14	Z8/12	Z5/8	Z4/6	Z10/14	Z8/12	Z6/10	Z4/6
Stainless Steel Acero inoxidable	•	•	••	•••	•	•	••	•••	•	••	•••	•••	•	••	•••	•••	•	••	•••	•••
Cast Iron Hierro fundido	•	••	•••	•••	•	••	•••	•••	•	••	•••	•••	•	••	•••	•••	•	••	•••	•••
Iron Hierro	•	•	••••	•••	•	••	••••	•••	•	•••	•••	•••	•	•••	•••	•••	•	•••	•••	•••
Aluminum Aluminio	•	•	•••	••••	•	•	•••	••••	•	••	••••	••••	•	••	••••	••••	•	••	••••	••••
Plastic Plastico	•	••	•••	••••	•	••	•••	••••	•	••	••••	••••	•	••	••••	••••	•	••	••••	••••
Brass Latón	•	••	•••	•••	•	•••	•••	•••	•	••	•••	•••	•	••	•••	•••	•	••	•••	•••
Copper Cobre	•	••	••••	•••	•	•••	•••	•••	•	•••	•••	•••	•	•••	•••	•••	•	•••	•••	•••

• Not recommended, •• Acceptable, ••• Good, •••• PRO Level
• No recomendado, •• Admisible, ••• Bueno, •••• Nivel PRO

Z = Teeth Per Inch.
Z = Dientas para inch.



PIPES & PROFILES / TUBERIA Y PERFILES

BLADE HOJA	ABS 1750XL - 1750XL				2200XL - 2200 DAXL				N250DA XL N251DA XL N257DA DG				N266XL - N276DA XL				N310 DA DG			
	1735x19x0,9mm				2140x19x0,9mm				2480x27x0,9mm				2565x27x0,9mm				2750x27x0,9mm			
TPI (Teeth Per Inch) Dientas para inch	Z14	Z8/12	Z6/10	Z4/6	Z14	Z8/12	Z6/10	Z4/6	Z10/14	Z8/12	Z6/10	Z4/6	Z10/14	Z8/12	Z5/8	Z4/6	Z10/14	Z8/12	Z6/10	Z4/6
Stainless Steel Acero inoxidable	••••	•••	•	•	••••	•••	•	•	•••	••	•	•	•••	••	•	•	•••	••	•	•
Cast Iron Hierro fundido	•••	•••	••	•	•••	•••	••	•	••	•••	••	•	••	•••	••	•	••	•••	••	•
Iron Hierro	••••	•••	•	•	••••	•••	•	•	••••	•••	•	•	••••	•••	•	•	••••	•••	•	•
Aluminum Aluminio	•••	••	••	•	•••	••	••	•	••••	•••	••	•	••••	•••	••	•	••••	•••	••	•
Plastic Plastico	•••	••••	•••	•	•••	••••	••	•	••••	••	••	•	••••	••	••	•	••••	••	••	•
Brass Latón	•••	••••	•••	•	•••	••••	•••	•	•••	•••	•••	•	•••	•••	•••	•	•••	•••	•••	•
Copper Cobre	•••	••••	•••	•	•••	••••	•••	•	••••	•••	•••	•	••••	•••	•••	•	••••	•••	•••	•

• Not recommended, •• Acceptable, ••• Good, •••• PRO Level
• No recomendado, •• Admisible, ••• Bueno, •••• Nivel PRO

Z = Teeth Per Inch.
Z = Dientas para inch.

1330 LINE / LÍNEA 1330



ABS
Automatic Blade System



ABS 105
Ø 105
PAG. 24



NG
NEW GENERATION

DCS
DIGITAL CUTTING SYSTEM

DCS NG110
110



PAG. 26



NG105 XL
Ø 105

PAG. 30



NEW



780XL
Ø 105
PAG. 37



782XL
Ø 105
PAG. 35



XL
EXTRA LARGE

783XL
Ø 105

PAG. 35



782XL ⚡ 48 VOLT
Ø 105

PAG. 36



1440 LINE / LÍNEA 1440

1750 LINE / LÍNEA 1750

ABS NG 120

∅120

PAG. 23



VIDEO

ABS NG 160

∇160

PAG. 22



VIDEO

MAGNETIKO

NEW



MAGNETIC CHIP COLLECTOR
suitable for all bandsaws
VARILLA MAGNÉTICA
para todas las sierras de cinta.

NG120XL

∅120

PAG. 29



VIDEO

NG160

∇160

PAG. 28



2200 LINE / LÍNEA 2200

787 DA XL ∇213

allroad



VIDEO

PAG. 32

784XL

∅120

PAG. 34



785XL

∇205

PAG. 33



787 XL ∇213

allroad



ABS Ng160

ABS
Automatic Blade System

ART.	CODE / CÓDIGO
ABS NG160	8.48.60.80



TECHNICAL FEATURES

- Push-click: 4 down feed speeds with mechanical selector
- Automatic cut-off switch after finishing cutting operation
- Safety emergency button to stop cutting
- Energy saving 100% motor efficiency is granted by the exclusive ABS system
- Maximum cutting versatility on all metal materials
- More than 10% saving on blade consumption

STANDARD EQUIPMENT

- Adjustable bar stop-rod for mass-produced cuts (L=500 mm)
- Handles for easy handling
- Filter-circuit for electromagnetic interference damping according to rules in force

CARACTERÍSTICAS TÉCNICAS

- Push-click 4 velocidades de corte, con selector mecánico
- Interruptor de parada automática al final del corte
- Botón de seguridad para detener el corte
- El exclusivo sistema abs asegura el 100% del rendimiento del motor
- Máxima versatilidad de corte sobre todo tipo de metal
- Más del 10% de ahorro en el consumo de la hoja de sierra

EQUIPEMENTS DE SÉRIE

- Varilla de sujeción regulable para realizar cortes en serie (L=500 mm)
- Asas para el transporte
- Circuito-filtro para la eliminación de interferencias electromagnéticas conforme con las normativas vigentes



CUTTING CAPACITY / CAPACIDAD DE CORTE

0°	160x140 mm	150 mm	150X150 mm
45°	105x120 mm	100 mm	100X100 mm

For solid materials we suggest to reduce the maximum cutting diameter
Para el material macizo se aconseja reducir el diámetro máximo de corte

FULLY AUTONOMOUS CUTTING CYCLE WITHOUT OPERATOR / CICLO DE CORTE COMPLETAMENTE AUTÓNOMO, SIN PRESENCIA DEL OPERARIO

ABS
Automatic Blade System



2000



1735x13x0,9



14*



35 ÷ 80

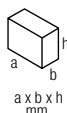

1000x390x570



36

*Standard bimetal cobalt blade / De serie hoja bimetálica al cobalto • 230 Volt - Hz 50 single-phase motor / Motor monofásico 230 Volt - Hz 50

ABS NG120



ART.	CODE / CÓDIGO
ABS NG120	8.48.50.80



VIDEO

TECHNICAL FEATURES

- Push-click: 4 down feed speeds with mechanical selector
- Automatic cut-off switch after finishing cutting operation
- Safety emergency button to stop cutting
- Energy saving 100% motor efficiency is granted by the exclusive ABS system
- Maximum cutting versatility on all metal materials
- More than 10% saving on blade consumption

STANDARD EQUIPMENT

- Adjustable bar stop-rod for mass-produced cuts (L=500 mm)
- Tools for changing blade
- Filter-circuit for electromagnetic interference damping according to rules in force

CARACTERÍSTICAS TÉCNICAS

- Push-click 4 velocidades de corte, con selector mecánico
- Interruptor de parada automática al final del corte
- Botón de seguridad para detener el corte
- El exclusivo sistema abs asegura el 100% del rendimiento del motor
- Máxima versatilidad de corte sobre todo tipo de metal
- Más del 10% de ahorro en el consumo de la hoja de sierra

EQUIPEMENTS DE SÉRIE

- Varilla tope regulable para realizar cortes en serie (L=500 mm)
- Herramienta para el cambio de la hoja
- Circuito-filtro para la eliminación de interferencias electromagnéticas conforme con las normativas vigentes

PATENTED



MAX 120 mm

**WITHOUT LUBRICATION
SIN LUBRICACION**

FASTER / MÁS VELOZ
60%

NG
NEW GENERATION

CUTTING CAPACITY / CAPACIDAD DE CORTE

0°	120x102 mm	120 mm	112x112 mm
45°	78x78 mm	80 mm	78x78 mm
60°	50x43 mm	50 mm	48x48 mm

FULLY AUTONOMOUS CUTTING CYCLE WITHOUT OPERATOR / CICLO DE CORTE COMPLETAMENTE AUTÓNOMO, SIN PRESENCIA DEL OPERARIO



1300



1440x13x0,65



14*



35 ÷ 80

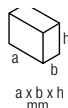

900x400x520



19

*Standard bimetal cobalt blade / De serie hoja bimetálica al cobalto • 230 Volt - Hz 50 single-phase motor / Motor monofásico 230 Volt - Hz 50



ABS 105

ABS
Automatic Blade System

ART.	CODE / CÓDIGO
ABS 105	8.48.46.81

PATENTED



VIDEO

TECHNICAL FEATURES

- Push-click: 4 down feed speeds with mechanical selector
- Automatic cut-off switch after finishing cutting operation
- Safety emergency button to stop cutting
- Energy saving 100% motor efficiency is granted by the exclusive ABS system
- Maximum cutting versatility on all metal materials (AL, Acc, Innox)
- More than 10% saving on blade consumption

STANDARD EQUIPMENT

- Adjustable bar stop-rod for mass-produced cuts (L=500 mm).
- Blade cleaning felt spares kit
- Filter-circuit for electromagnetic interference damping according to rules in force

CARACTERÍSTICAS TÉCNICAS

- Push-click 4 velocidades de corte, con selector mecánico
- Interruptor de parada automática al final del corte
- Botón de seguridad para detener el corte
- El exclusivo sistema abs asegura el 100% del rendimiento del motor
- Máxima versatilidad de corte sobre todo tipo de metal (AL, Acc, Innox)
- Más del 10% de ahorro en el consumo de la hoja de sierra

EQUIPEMENTS DE SÉRIE

- Varilla de sujeción de la barra regulable, para realizar cortes en serie (L=500 mm)
- Kit de recambio filtro de limpieza de la hoja
- Circuito-filtro para la eliminación de interferencias electromagnéticas conforme con las normativas vigentes



CUTTING CAPACITY / CAPACIDAD DE CORTE

0°	100x85 mm	105 mm	95x95 mm
45°	65x60 mm	65 mm	65x65 mm

FULLY AUTONOMOUS CUTTING CYCLE WITHOUT OPERATOR / CICLO DE CORTE COMPLETAMENTE AUTÓNOMO, SIN PRESENCIA DEL OPERARIO

ABS
Automatic Blade System



950



1335x13x0,65



8/12*



60/80

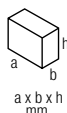

730x390x500



17

*Standard bimetal cobalt blade / De serie hoja bimetálica al cobalto • 230 Volt - Hz 50 single-phase motor / Motor monofásico 230 Volt - Hz 50



ABS

Automatic Blade System

SYSTEM *REVOLUTION*

Fully autonomous cutting cycle,
without operator.

Ciclo de corte completamente
autónomo, sin presencia del operador.





LASER

LIGHT

PATENTED

FASTER | MÁS VELOZ
40%

TECHNICAL FEATURES

- Up to 40% faster cutting compared to the traditional bandsaw thanks to the opposite rotation direction of the bandsaw blade ("NG SYSTEM")
- 5 pre-set cutting modes
- Innovative blade tensioning device with clutch to check and adjust the proper tension of the blade (patented)
- Low voltage start button power
- Adjustable left cutting angle from 0° to 45°
- Sturdy die-cast aluminium base with integrated vice

STANDARD EQUIPMENT

- Adjustable bar stop-rod for massproduced cuts (L=500 mm)
- Filter-circuit for electromagnetic interference damping according to rules in force

CARACTERÍSTICAS TÉCNICAS

- Reducción del tiempo de corte hasta un 40% respecto a una sierra tradicional gracias al sentido de rotación contrario de la hoja ("NG SYSTEM")
- 5 modos de corte programados
- Innovador tensor mediante embrague para el control y la regulación del correcto tensado de la hoja (patentado)
- Botón de inicio de baja tensión
- Ángulo de corte regulable de 0° a 45° izquierda
- Robusta base de aluminio fundido a presión con vicio integrado

EQUIPEMENTS DE SÉRIE

- Varilla tope regulable para realizar cortes en serie (L=500 mm)
- Circuito-filtro para la eliminación de interferencias electromagnéticas conforme con las normativas vigentes

CUTTING CAPACITY / CAPACIDAD DE CORTE

0°	110x85 mm	105 mm	100x100 mm
45°	75x37 mm	74 mm	72x72 mm



950 W



1335x13x0,65



8/12"



35 ÷ 80

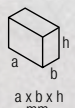

730x390x500



17

*Standard bimetal cobalt blade / De serie hoja bimetálica al cobalto
 230 Volt - Hz 50 single-phase motor / Motor monofásico 230 Volt - Hz 50

DCS

DIGITAL CUTTING SYSTEM

Revolutionary electronic control system that guarantees optimal cutting in the main conditions of use through 5 pre-set working modes.

Sistema revolucionario de control electrónico que asegura un corte óptimo en las principales condiciones de uso a través de 5 modos de trabajo preestablecidos.

MODE

SPEED

Manual adjustment of the blade rotation speed.

Regulación manual de la velocidad de rotación de la hoja.

1

For demanding cuts with particularly resistant materials, stainless steel and solid sections with thickness > 30 mm.
Para cortes exigentes con materiales particularmente resistentes, acero inoxidable y secciones sólidas con espesor > 30 mm.

30 mt/min
STEEL-INOX

> 30mm



2

For cutting steel with tubular sections up to 30 mm thickness and full up to 30 mm.
Para cortar acero con secciones tubulares de hasta 30 mm de espesor y llenos hasta 30 mm.

45 mt/min
STEEL

> 8mm < 30mm



3

Ideal for cutting iron and steel for any shape with thickness between 5 and 8 mm.
Ideal para cortar hierro y acero de cualquier forma con espesor entre 5 y 8 mm.

55 mt/min
STEEL

> 5mm < 8mm



4

Ideal for tubular sections including L and H sections with thin thickness from 3 to 5 mm. All materials, including aluminium.
Ideal para secciones tubulares que incluyen secciones L y H con espesor fino de 3 a 5 mm. Todos los materiales, incluido el aluminio.

65 mt/min
STEEL - ALU

> 3mm < 5mm



5

Only for very fine section tubulars with thicknesses under 3 mm. All materials, including aluminium.

Solo para tubulares de sección muy fina con espesores inferiores a 3 mm. Todos los materiales, incluido el aluminio.

80 mt/min
STEEL - ALU

< 3mm



FORCE CONTROL

Overload indicator to avoid excessive engine strain, possible blade breakages and inaccurate cuts.

Indicator de sobrecarga para evitar la tensión excesiva del motor, posibles roturas de la hoja y cortes imprecisos.



NG160



ART.	CODE / CÓDIGO
NG160	8.48.60.21

TECHNICAL FEATURES

- Up to 40% faster cutting compared to the traditional bandsaw thanks to the opposite rotation direction of the bandsaw blade ("NG SYSTEM")
- Base with integrated quick sliding vice
- Powerful 2000 W single-phase motor equipped with digital electronic speed regulator "Constant Speed" with amperometric limiting device and thermal protection
- Guard safety microswitch for blade protection

STANDARD EQUIPMENT

- Adjustable bar stop-rod for mass-produced cuts (L=500 mm)
- Handles for easy handling
- Filter-circuit for electromagnetic interference damping according to rules in force.

CARACTERÍSTICAS TÉCNICAS

- Reducción del tiempo de corte hasta un 40% respecto a una sierra tradicional gracias al sentido de rotación contrario de la hoja ("NG SYSTEM")
- Base con mordaza y sistema deslizante rápido integrada
- Potente motor monofásico (2000 W) con regulación electrónica digital de velocidad "Constant Speed" con limitador amperimétrico y protección térmica
- Cambio de la hoja rápido y sin necesidad de herramientas.

EQUIPEMENTS DE SÉRIE

- Varilla de sujeción regulable para realizar cortes en serie (L=500 mm)
- Asas para el transporte
- Circuito-filtro para la eliminación de interferencias electromagnéticas conforme con las normativas vigentes

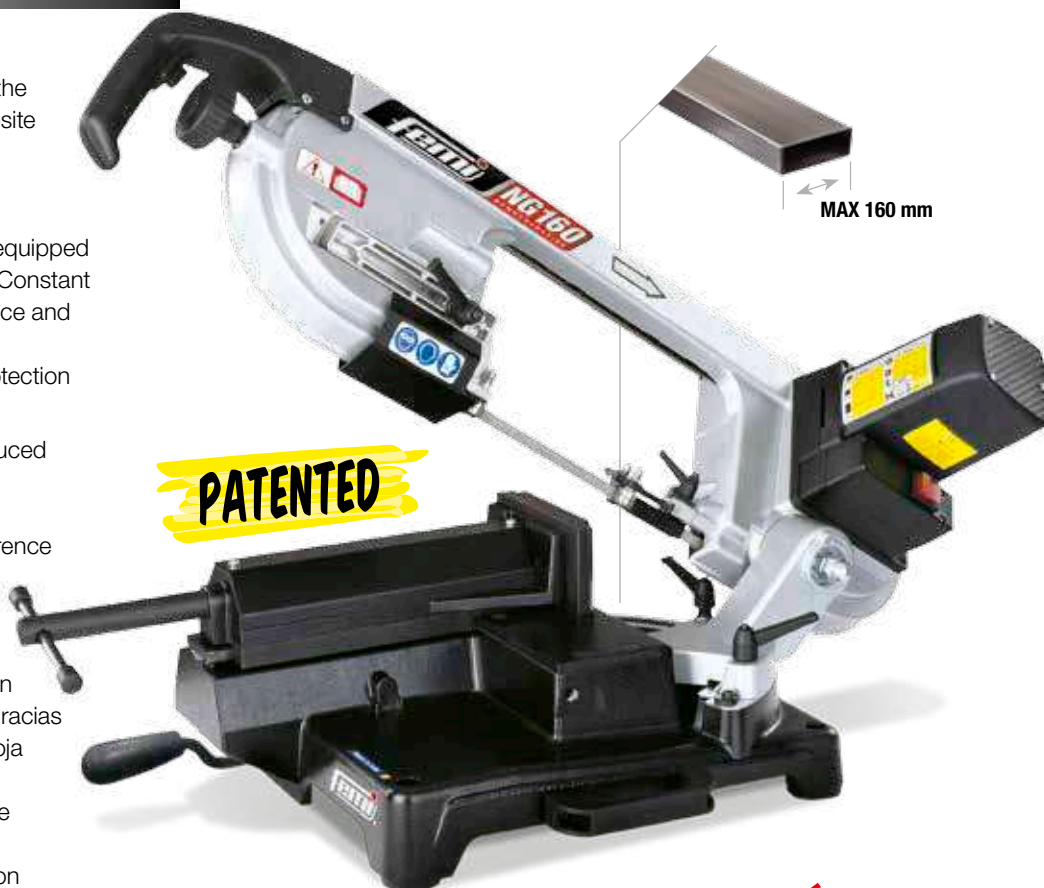

CUTTING CAPACITY / CAPACIDAD DE CORTE

0°	160x140 mm	150 mm	150X150 mm
45°	105x120 mm	100 mm	100X100 mm

For solid materials we suggest to reduce the maximum cutting diameter
Para el material macizo se aconseja reducir el diámetro máximo de corte



"NG SYSTEM": opposite blade rotation direction
"NG System": rotación inversa de la hoja



- Adjustable double sliding saw blade guides
- Guías de corte dobles ajustables



- Innovative clutched band tensioning system (patented)
- Nuevo sistema de tensado de la hoja por fricción (patentado)



2000

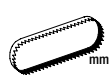

1735x13x0,9

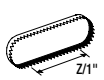

6/10*



35 ÷ 80

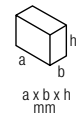

1000x390x570



35

*Standard bimetal cobalt blade / De serie hoja bimetálica al cobalto • 230 Volt - Hz 50 single-phase motor / Motor monofásico 230 Volt - Hz 50

NG120 XL



ART.	CODE / CÓDIGO
NG120 XL	8.48.50.22



VIDEO

TECHNICAL FEATURES

- Up to 60% faster cutting compared to the traditional bandsaw thanks to the opposite rotation direction of the bandsaw blade ("NG SYSTEM")
- Innovative blade tensioning device with clutch to check and adjust the proper tension of the blade (patented)
- Adjustable left cutting angle from 0° to 60° with quick block at 45° and 60°
- Powerful 1300 W single-phase motor equipped with digital electronic speed regulator "Constant Speed" with amperometric limiting device
- Double front and rear sliding saw blade guides

STANDARD EQUIPMENT

- Adjustable bar stop-rod for mass-produced cuts (L=500 mm)
- Tools for changing blade
- Filter-circuit for electromagnetic interference damping according to rules in force

CARACTERÍSTICAS TÉCNICAS

- Reducción del tiempo de corte hasta un 60% respecto a una sierra tradicional gracias al sentido de rotación contrario de la hoja ("NG SYSTEM")
- Innovador tensor mediante embrague para el control y la regulación del correcto tensado de la hoja (patentado)
- Ángulo de corte regulable de 0° a 60° izquierda con bloqueo rápido 45° y 60°
- Potente motor 1300 W con regulación electrónica de velocidad "velocidad constante", con limitador amperimétrico y protección térmica
- Doble guía-hoja ambas deslizables anterior y posterior

EQUIPEMENTS DE SÉRIE

- Varilla tope regulable para realizar cortes en serie (L=500 mm)
- Herramienta para el cambio de la hoja
- Circuito-filtro para la eliminación de interferencias electromagnéticas conforme con las normativas vigentes



CUTTING CAPACITY / CAPACIDAD DE CORTE

0°	120x102 mm	120 mm	112x112 mm
45°	78x78 mm	80 mm	78x78 mm
60°	50x43 mm	50 mm	48x48 mm



NG

NEW GENERATION

"NG SYSTEM": opposite blade rotation direction
 "NG System": rotación inversa de la hoja



- Maximum cutting capacity 120 x 102 mm
- Capacidad de corte máxima 120 x 102 mm



- Easy to carry
- Fácil de transportar



1300



1440x13x0,65



14*



35 ÷ 80

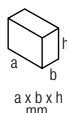

900x400x520



18

*Standard bimetal cobalt blade / De serie hoja bimetálica al cobalto • 230 Volt - Hz 50 single-phase motor / Motor monofásico 230 Volt - Hz 50



NG105 XL



ART.	CODE / CÓDIGO
NG105 XL	8.48.47.20

NEW

TECHNICAL FEATURES

- Up to 35% faster cutting compared to the traditional bandsaw thanks to the opposite rotation direction of the bandsaw blade ("NG SYSTEM")
- Innovative blade tensioning device with clutch to check and adjust the proper tension of the blade (Patented)
- Adjustable cutting angle from 0° to 45°
- Powerful 950 Watt motor.

STANDARD EQUIPMENT

- Adjustable bar stop-rod for mass-produced cuts (L= 500mm)
- Filter-circuit for electromagnetic interference damping according to rules in force.

CARACTERÍSTICAS TÉCNICAS

- Reducción del tiempo de corte hasta un 35% respecto a una sierra tradicional gracias a la dirección contraria de rotación de la hoja ("NG SYSTEM")
- Innovador tensor mediante embrague para el control y regulación del correcto tensado de la hoja (patentado)
- Ángulo de corte regulable de 0° a 45°
- Potente motor 950 Watt

EQUIPO DE SÉRIE

- Varilla de sujeción regulable para realizar cortes en serie (L= 500mm)
- Circuito-filtro para la eliminación de interferencias electromagnéticas conforme con las normativas vigentes



**WITHOUT LUBRICATION
SIN LUBRICACION**

MAX 105 mm



VIDEO

PATENTED

**FASTER 1 MÁS VELOZ
35%**

NG

NEW GENERATION

"NG SYSTEM": opposite blade rotation direction
"NG System": rotación inversa de la hoja

CUTTING CAPACITY / CAPACIDAD DE CORTE

0°	100x85 mm	105 mm	95x95 mm
45°	65x60 mm	65 mm	65x65 mm



- The best cutting quality for any kind of material
- La mejor calidad de corte para cualquier tipo de material



- Innovative clutched band tensioning system (PATENTED)
- Nuevo sistema de tensado de la hoja por fricción (PATENTADO)



950



1335x13x0,65



14*



60 / 80

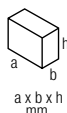

900x400x520



16

* Standard bimetal cobalt blade / De serie hoja bimetálica al cobalto • 230 Volt - Hz 50 Single-phase motor / Motor monofásico 230 Volt - Hz 50

NG

NEW GENERATION

FEMI BANDSAWS WITH **PATENTED** NG CUTTING SYSTEM SIERRAS DE CINTA FEMI CON SISTEMA DE CORTE **PATENTADO**

PATENTED

FEMI bandsaws with **PATENTED** NG cutting system have the blade reverse direction of rotation, assuring a higher cutting speed from 35% to 60% compared to traditional saws

Las sierras de cinta FEMI con sistema de corte **PATENTADO** NG tienen el sentido de rotación inverso de la hoja, asegurando una mayor velocidad de corte del 35% hasta 60% en comparación con las sierras tradicionales

NG105XL

35%

NG160

40%

NG120XL

60%



The NG SYSTEM exclusive patent enables you to save real time!
¡La patente exclusiva de NG SYSTEM le permite ahorrar tiempo real!

NG SYSTEM bandsaws are the **NEW GENERATION** metal cutting machines with innovative technical features unique in the world: undisputed supremacy for speed, accuracy and cutting versatility.

Las sierras de cinta **NG SYSTEM** son máquinas por el corte de los metales de **NUEVA GENERACIÓN** con características técnicas innovadoras únicas en el mundo: supremacía indiscutible en velocidad, precisión y versatilidad de corte.

Ergonomic handle and innovative blade tensioning device (patented)

Mango ergonómico y dispositivo tensor de hoja innovador (patentado)



Adjustable double sliding saw blade guides

Doble guía-hoja de ambas deslizables anterior y posterior



Digital electronic speed regulation "constant speed"

Regulación electrónica de velocidad digital "velocidad constante"

787 DA XL / 787 XL

AUTOMATIC DOWN FEED

BAJADA AUTOMÁTICA



ART.	CODE / CÓDIGO
787 DA XL Allroad	8.48.70.25
ART.	CODE / CÓDIGO
787 XL Allroad	8.48.70.23



TECHNICAL FEATURES

- Exclusive “roto-translating” arm system (patented) (787 XL)
- Blade height 19 mm
- Possibility to make cuts with lubrication
- Base complete with wheels ideal for transport

STANDARD EQUIPMENT

- Circuito-filtro para la eliminación de interferencias electromagnéticas conforme con las normativas vigentes

CARACTERÍSTICAS TÉCNICAS

- Sistema exclusiva del brazo “roto-traslación” (patentado) (787 XL)
- Altura hoja 19 mm
- Posibilidad de hacer cortes con la lubricación
- Base completa con ruedas ideal para el transporte

EQUIPMENTS DE SÉRIE

- Filter-circuit for electromagnetic interference damping according to rules in force

787 DA XL



- Control panel in ergonomic position for starting and adjusting cutting operation
- Panel de control en posición ergonómica para iniciar y ajustar las operaciones de corte



- Closed circuit hydraulic system for arm down feed and descent control
- Sistema hidráulico de circuito cerrado para control de la bajada del brazo

CUTTING CAPACITY / CAPACIDAD DE CORTE

0°	213x150 mm	175 mm	150x150 mm
45°	145x80 mm	140 mm	140x140 mm



1850



2140X19X0,9



8/12*



60/80

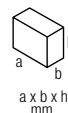

500x1300x700



59

*Standard bimetal cobalt blade / De serie hoja bimetálica al cobalto • 230 Volt - Hz 50 single-phase motor / Motor monofásico 230 Volt - Hz 50

785 XL



ART.	CODE / CÓDIGO
785 XL	8.48.60.26

TECHNICAL FEATURES

- Unique and great cutting capacity:
 205 x 150 mm
- Powerful 1600 Watt motor with two speeds electric switchover and thermal protection
- Blade tensioning system fitted with light indicator
- Easy to carry

STANDARD EQUIPMENT

- Adjustable bar stop-rod for massproduced cuts (L=500 mm)
- Handles for easy handling
- Filter-circuit for electromagnetic interference damping according to rules in force

CARACTERÍSTICAS TÉCNICAS

- Gran capacidad de corte:
 205 x 150 mm
- Potente motor 1600 W dos velocidades de conmutación eléctrica, con protección térmica
- Tensor de la hoja práctico de usar con indicador visual
- Fácil de transportar

EQUIPEMENTS DE SÉRIE

- Varilla tope regulable, para realizar cortes en serie (L=500 mm)
- Asas para el transporte
- Circuito-filtro para la eliminación de interferencias electromagnéticas conforme con las normativas vigentes



**WITHOUT LUBRICATION
SIN LUBRICACION**

PATENTED

CUTTING CAPACITY / CAPACIDAD DE CORTE

0°	205x150 mm	152 mm	150x150 mm
45°	105x95 mm	106 mm	102x102 mm



- Exclusive "rototranslating" arm system (patented)
- Sistema exclusivo del brazo "rototraslación" (patentado).



- Ideal for cutting large profiles like conduits and profiles
- Ideal para el corte de grandes perfiles como los conductos y tubulares.



1600



1735x13x0,9



14*



60 ÷ 80



1000x390x570



38

*Standard bimetal cobalt blade / De serie hoja bimetálica al cobalto • 230 Volt - Hz 50 single-phase motor / Motor monofásico 230 Volt - Hz 50

784 XL

XL

ART.	CODE / CÓDIGO
784 XL	8.48.50.23

TECHNICAL FEATURES

- Innovative blade tensioning device with clutch to check and adjust the proper tensioning of the blade (patented)
- Powerful 1200 W universal motor
- Digital electronic speed regulator "Constant Speed" with amperometric limiting device
- Die-cast vice with prismatic guides
- Easy to carry: only 17 kg

STANDARD EQUIPMENT

- Adjustable bar stop-rod for mass-produced cuts
- Tool for changing blade
- Filter-circuit for electromagnetic interference damping according to rules in force

CARACTERÍSTICAS TÉCNICAS

- Innovador tensor mediante embrague para el control y la regulación del correcto tensado de la hoja (patentado)
- Potente motor universal 1200 W
- Regulación electrónica de velocidad "velocidad constante", con limitador amperimétrico y protección térmica
- Mordaza moldeada a presión con guías prismáticas
- Sólo 17 kg de peso para la máxima portabilidad

EQUIPEMENTS DE SÉRIE

- Varilla tope regulable para realizar cortes en serie
- Herramienta para el cambio de la hoja
- Circuito-filtro para la eliminación de interferencias electromagnéticas conforme con las normativas vigentes



PATENTED

WITHOUT LUBRICATION SIN LUBRICACION

MAX 120 mm

WORK TABLE AND GONIOMETER KIT (ALSO FOR ART.780XL, 782XL, 783XL ON REQUEST)

KIT MESA DE TRABAJO Y GONIÓMETRO (TAMBIÉN PARA ART.780XL, 782XL, 783XL BAJO PEDIDO)



- Cutting capacity up to \varnothing 120 mm and up to \square 120 x 115 mm
- Capacidad de corte hasta \varnothing 120 mm y hasta \square 120 x 115 mm

- Powerful motor with digital electronic speed regulator
- Potente motor con regulación electrónica de velocidad

CUTTING CAPACITY / CAPACIDAD DE CORTE

0°	120x115 mm	120 mm	119x119 mm
45°	85x70 mm	85 mm	80x80 mm

1200	1440x13x0,65	8/12*	30 ÷ 80	900x400x520		17

*Standard bimetal cobalt blade / De serie hoja bimetálica al cobalto • 230 Volt - Hz 50 single-phase motor / Motor monofásico 230 Volt - Hz 50

782 XL / 783 XL



ART.	CODE / CÓDIGO
782 XL	8.48.36.22

TECHNICAL FEATURES

- Easy blade tensioning device
- Powerful 950 W single phase motor with digital electronic speed regulator "Constant speed" with amperometric limiting device (ART. 783XL)
- Two speeds, electronic switch (ART. 782XL).
- Anti-reset safety function
- Arm-locking device for easy handling

STANDARD EQUIPMENT

- Adjustable bar stop-rod for mass-produced cuts (L=500 mm)
- Blade cleaning felt spares kit
- Filter-circuit for electromagnetic interference damping according to rules in force

CARACTERÍSTICAS TÉCNICAS

- Tensor de la hoja práctico de usar
- Potente motor 950 W con regulación electrónica de velocidad "Velocidad constante", con limitador amperimétrico (ART. 783XL)
- 2 velocidades de conmutación electrónica (ART. 782XL)
- Sistema de seguridad anti-arranque
- Dispositivo de bloqueo arco para facilitar el transporte

EQUIPEMENTS DE SÉRIE

- Varilla de sujeción de la barra regulable, para realizar cortes en serie (L=500 mm)
- Kit de recambio filtro de limpieza de la hoja
- Circuito-filtro para la eliminación de interferencias electromagnéticas conforme con las normativas vigentes



PATENTED

CUTTING CAPACITY / CAPACIDAD DE CORTE

0°	100x85 mm	105 mm	95x95 mm
45°	65x60 mm	65 mm	65x65 mm

782 XL	950	1335x13x0,65	8/12*	60/80	730x390x500	16
783 XL	950	1335x13x0,65	8/12*	30 ÷ 80	730x390x500	16

*Standard bimetal cobalt blade / De serie hoja bimetalica al cobalto • 230 Volt - Hz 50 single-phase motor / Motor monofásico 230 Volt - Hz 50



ART.	CODE / CÓDIGO
783 XL	8.48.36.23



ELECTRONIC SPEED REGULATION
REGULACIÓN ELECTRÓNICA DE VELOCIDAD

782 XL - 48 VOLT



ART.	CODE / CÓDIGO
782 XI - 48 Volt	8.48.46.00

TECHNICAL FEATURES

- 48 Volt - 560 Watt motor
- Easy blade tensioning device
- Anti reset safety function
- Cut without lubrication
- Arm locking device for an easy handling
- Thanks to 48 Volt power supply it is very suitable for:
 - shipyards or on board ship
 - underground environments

STANDARD EQUIPMENT

- Adjustable bar stop-rod for mass-produced cuts (L=500 mm)
- Blade cleaning felt spare kit
- Filter-circuit for electromagnetic interference damping according to rules in force

CARACTERÍSTICAS TÉCNICAS

- Motor 48 Volt - 560 Watt
- Tensor de la hoja práctico de usar
- Sistema de seguridad anti-arranque
- Corte sin lubricación
- Dispositivo de bloqueo arco para facilitar el transporte
- Gracias a la fuente de alimentación de 48 Volt, está particularmente indicado en las siguientes aplicaciones:
 - astilleros, a bordo de los barcos y plataformas off-shore
 - ambientes subterráneos

EQUIPEMENTS DE SÉRIE

- Varilla de sujeción de la barra para realizar cortes en serie (L=500 mm).
- Kit de recambio fi eltro de limpieza de la hoja
- Circuito-filtro para la eliminación de interferencias electromagnéticas conforme con las normativas vigentes



**WITHOUT LUBRICATION
SIN LUBRICACION**

CUTTING CAPACITY / CAPACIDAD DE CORTE

0°	105x93 mm	105 mm	102x102 mm
45°	105x93 mm	72 mm	68x68 mm

48 VOLT

THANKS TO 48 VOLT POWER SUPPLY IT IS VERY SUITABLE FOR:

- SHIPYARDS OR ON BOARD SHIP
- UNDERGROUND ENVIRONMENTS

GRACIAS A LA FUENTE DE ALIMENTACIÓN DE 48 VOLT, ESTÁ PARTICULARMENTE INDICADO EN LAS SIGUIENTES APLICACIONES:

- ASTILLEROS, A BORDO DE LOS BARCOS Y PLATAFORMAS OFF-SHORE
- AMBIENTES SUBTERRÁNEOS



560



1335x13x0,65



8/12*



70

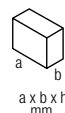

730X390X500



17

*Standard bimetal cobalt blade / De serie hoja bimetálica al cobalto • 230 Volt - Hz 50 single-phase motor / Motor monofásico 230 Volt - Hz 50

780 XL



ART.	CODE / CÓDIGO
780 XL	8.48.33.21



VIDEO

TECHNICAL FEATURES

- Greater cutting capacity: Ø 105 mm
- Practical blade tensioning device
- Powerful 850W motor, 2 speeds electronically switched
- Anti-reset safety function
- Cut without lubrication
- Arm-blocking device for easy handling
- Labelling with clear cutting indications

STANDARD EQUIPMENT

- Adjustable bar stop-rod for mass-produced cuts (L=500 mm)
- Blade cleaning felt spare kit
- Filter-circuit for electromagnetic interference damping according to rules in force

CARACTERÍSTICAS TÉCNICAS

- Capacidad de corte mayor: Ø 105 mm
- Tensor de la hoja práctico de usar
- Potente motor 850 W, dos velocidades de conmutación electrónica
- Sistema de seguridad anti-arranque
- Corte sin lubricación
- Dispositivo de bloqueo arco para facilitar transporte
- Forma gráfica con claras indicaciones de los parámetros de corte

EQUIPEMENTS DE SÉRIE

- Varilla tope regulable, para realizar cortes en serie (L=500 mm)
- Kit de recambio filtro de limpieza de la hoja
- Circuito-filtro para la eliminación de interferencias electromagnéticas conforme con las normativas vigentes



CUTTING CAPACITY / CAPACIDAD DE CORTE

0°	105x93 mm	105 mm	102x102 mm
45°	70x60 mm	72 mm	68x68 mm



- Maximum versatility of use
- Máxima versatilidad de uso



- Work table and goniometer kit (also for art. 782XL/783XL/784XL on request)
- Kit mesa de trabajo y goniómetro (aussi pour art. 782XL/783XL/784XL bajo pedido)



850



1335x13x0,65



8/12*



60/80

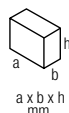

730X390X500



17

*Standard bimetal cobalt blade / De serie hoja bimetálica al cobalto • 230 Volt - Hz 50 single-phase motor / Motor monofásico 230 Volt - Hz 50



STANDY



ART.	CODE / CÓDIGO
390	7.13.36.87

TECHNICAL FEATURES

- Sturdy stoved painted steel structure
- Pre-arranged to be fixed on the floor
- Maximum charge 150 kg

CARACTERÍSTICAS TÉCNICAS

- Robusta estructura de acero pintada en caliente
- Está adaptada para ser fijada al piso
- Max posibilidad de carga: 150 kg

UNIVERSAL TABLE BASE EXPOSITORA UNIVERSAL

ART.	CODE CÓDIGO	FOR ART. PARA ART.	Kg
390	7.13.36.87	ABS105 / ABSNG160 / ABSNG120 / 780XL / 782XL / DCS NG110 / 783XL / 784XL / NG160 / NG120XL / 785XL / NG105XL	15

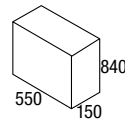

JOBBY



ART.	CODE / CÓDIGO
300 PLUS	7.13.36.48

TECHNICAL FEATURES

- Foldable for easy handling
- Sturdy steel section structure
- Height adjustable in three positions
- Maximum charge 50 kg

CARACTERÍSTICAS TÉCNICAS

- Plegable para un fácil transporte
- Estructura de perfil de acero robusto
- Altura regulable en tres posiciones
- Max posibilidad de carga 50 kg

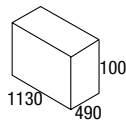

FOLDING TABLE "JOBBY" / BANCO PLEGABLE "JOBBY"

FOR ART. / PARA ART.	Kg
ABS105 / ABSNG160 / ABSNG120 / 780XL / 782XL / DCS NG110 / 783XL / 784XL / NG160 / NG120XL / 785XL / NG105XL	11

WORK TABLE KIT KIT MESA DE TRABAJO



CODE / CÓDIGO
7.07.51.72

TECHNICAL FEATURES

- Alluminium work table with goniometer guides
- Equipped with anti-tips support
- Quick and easy assembly

CARACTERÍSTICAS TÉCNICAS

- Mesa de aluminio con guías para goniómetro
- Apoyo contra vuelcos
- Montaje simple y rápido

WORK TABLE KIT / KIT MESA DE TRABAJO

CODE CÓDIGO	FOR ART. PARA ART.
7.07.51.72	780XL / 782XL / 783XL / 784XL

GONIOMETER FOR WORK TABLE GONIÓMETRO PARA MESA DE TRABAJO



CODE / CÓDIGO
5.13.07.52

- Cutting angle adjustment 0°-60° right-left
- Regulacion de ángulo 0°-60° de-iz

MULTY

ART.	CODE / CÓDIGO
360	7.13.36.47



CARATTERISTICHE TECNICHE

- Sturdy solid aluminium structure
- Universal couple of brackets for the bandsaw and mitresaw fixing
- Possibility to electrically connect three tools
- Integrated handle for an easy transport
- Side supports extensible, height and width adjustable
- Maximum charge: 120 kg

CARACTÉRISTIQUES TECHNIQUES

- Robusta estructura en perfilado de aluminio
- Par de abrazaderas universales para fijar tronzadoras y sierra de cinta
- Posibilidad de conectar eléctricamente hasta 3 aparatos
- Empuñadura integrada para un fácil transporte
- Apoyos laterales extensibles, regulables en alto y ancho
- Max posibilidad de carga 120 kg



(cod. 7.13.06.58)

Universal brackets for fixing mitresaws and bandsaws. Additional kit on request.

Abrazaderas universales para fijar tronzadoras y SIERRA de cinta. Kit adicional bajo pedido

CODE / CÓDIGO

7.13.06.58

FOLDING TABLE "MULTY" / BANCO PLEGABLE "MULTY"

FOR ART.
PARA ART.



Kg
20

ABS105 / ABSNG160 / ABSNG120 / 780XL / 782XL 48Volt / 783XL / 784XL / NG160 / NG120XL / 785XL / DCS NG110 / NG105XL

SINGLE-ROLLER SUPPORT SOPORTE MONO-RODILLO

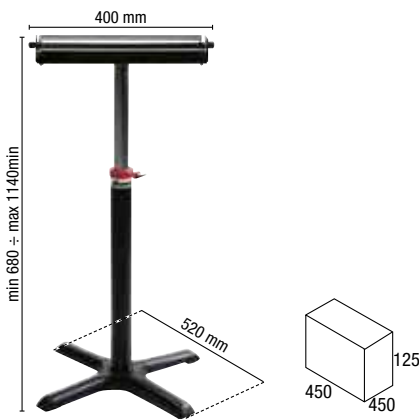

SINGLE-ROLLER SUPPORT / SOPORTE MONO-RODILLO

ART.	CODE / CÓDIGO	WEIGHT / PESO
301	7.13.37.16	6,5 kg

TECHNICAL FEATURES

- Zinc-plated steel roller Ø 57 mm
- Sturdy steel structure
- Base equipped with leveling feet
- Support height adjustment
- Maximum charge: 30 kg

CARACTERÍSTICAS TÉCNICAS

- Rodillo de acero galvanizado Ø 57 mm
- Robusta estructura de acero, hierro fundido
- Base provista de pies de nivelación
- Regulación de la altura de apoyo
- Max posibilidad de carga: 30 kg

NEW



MAGNETIKO

CODE CÓDIGO	SIZE DIMENSIONES	WEIGHT PESO
7.07.51.95	435 mm – Ø 20 mm	650 gr



TECHNICAL FEATURES

- Magnetic chip collector with ergonomic handle
- Stainless and lightweight shaft
- Ideal to reach hard areas
- To collect metal chips, nails and small metal components from chip-releasing machinery
- By extracting the central bar you can easily release the collected metal parts

CARACTERÍSTICAS TÉCNICAS

- Varilla magnética con mango ergonómico
- Eje inoxidable y liviano
- Ideal para zonas de difícil acceso
- Para recoger virutas de metal, clavos y pequeños componentes metálicos de la maquinaria liberadora de virutas.
- Extrayendo la barra central podrás liberar fácilmente las piezas metálicas recogidas

CODE
CÓDIGO

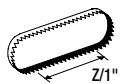

PACK
CAJA

ART. 787DAXL-787XL** 2200**

3.27.99.36	2140x19x0,9	6/10*	1 pc.
3.27.99.39	2140x19x0,9	6/10*	5 pc.
3.28.00.24	2140x19x0,9	8/12**	1 pc.
3.28.00.25	2140x19x0,9	8/12**	5 pc.
3.27.99.38	2140x19x0,9	4/6	1 pc.
3.27.99.41	2140x19x0,9	4/6	5 pc.
3.27.99.37	2140x19x0,9	14	1 pc.
3.27.99.40	2140x19x0,9	14	5 pc.

ART. 785XL-785P-785 1750

3.28.99.25	1735x13x0,9	14*	1 pc.
3.27.99.28	1735x13x0,9	14*	5 pc.
3.28.99.24	1735x13x0,9	6/10	1 pc.
3.27.99.27	1735x13x0,9	6/10	5 pc.
3.28.99.26	1735x13x0,9	6	1 pc.
3.27.99.29	1735x13x0,9	6	5 pc.

ART. 784XL-784 1440

3.29.00.00	1440x13x0,65	8/12*	1 pc.
3.29.00.04	1440x13x0,65	8/12*	5 pc.
3.28.99.99	1440x13x0,65	14	1 pc.
3.29.00.03	1440x13x0,65	14	5 pc.
3.29.00.01	1440x13x0,65	6	1 pc.
3.29.00.05	1440x13x0,65	6	5 pc.
3.29.00.02	1440x13x0,65	18	1 pc.
3.29.00.06	1440x13x0,65	18	5 pc.

ART. ABS 105-782XL-783XL-780XL-782XL 48 VOLT 1330

3.28.99.48	1335x13x0,65	8/12*	1 pc.
3.27.99.20	1335x13x0,65	8/12*	5 pc.
3.28.99.49	1335x13x0,65	6	1 pc.
3.27.99.21	1335x13x0,65	6	5 pc.
3.28.99.18	1335x13x0,65	14	1 pc.
3.27.99.22	1335x13x0,65	14	5 pc.
3.28.99.19	1335x13x0,65	18	1 pc.
3.27.99.23	1335x13x0,65	18	5 pc.

* Standard fitting on bandsaws / En dotación estándar en las SIERRA

TECHNICAL FEATURES

- Bimetal cobalt blades M42 for high cutting performance, suitable for dry cutting, too
- High resistance and productivity both for solid materials and for profiles
- Available in standard packs of 1 or 5 pieces

CARACTERÍSTICAS TÉCNICAS

- Hojas bimetálicas al cobalto M42 para elevadas prestaciones de corte, ideales también para cortes en seco
- Gran resistencia y productividad tanto en materiales macizos como en perfilados
- Disponibles en paquetes estándar de 1 ó 5 piezas



“NG SYSTEM” Bimetal bandsaw blades

Special blades ideal for use on “NG System” sawing machines

“NG SYSTEM” Hojas de cinta bimetálicas

Hojas específicas ideales para la utilización en SIERRA “NG SYSTEM”

CODE
CÓDIGO

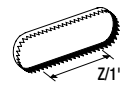

PACK
CAJA

ART. ABS NG160 1750

3.28.99.65	1735x13x0,9	14*	1 pc.
3.27.99.66	1735x13x0,9	14*	5 pc.
3.28.99.63	1735x13x0,9	6/10	1 pc.
3.27.99.64	1735x13x0,9	6/10	5 pc.
3.28.99.67	1735x13x0,9	6	1 pc.
3.27.99.68	1735x13x0,9	6	5 pc.

ART. NG160 1750

3.28.99.63	1735x13x0,9	6/10*	1 pc.
3.27.99.64	1735x13x0,9	6/10*	5 pc.
3.28.99.65	1735x13x0,9	14	1 pc.
3.27.99.66	1735x13x0,9	14	5 pc.
3.28.99.67	1735x13x0,9	6	1 pc.
3.27.99.68	1735x13x0,9	6	5 pc.

ART. ABS NG120-NG120XL-NG120 1440

3.28.99.57	1440x13x0,65	14*	1 pc.
3.27.99.61	1440x13x0,65	14*	5 pc.
3.28.99.55	1440x13x0,65	8/12	1 pc.
3.27.99.59	1440x13x0,65	8/12	5 pc.
3.28.99.56	1440x13x0,65	6	1 pc.
3.27.99.60	1440x13x0,65	6	5 pc.
3.28.99.58	1440x13x0,65	18	1 pc.
3.27.99.62	1440x13x0,65	18	5 pc.

ART. DCS NG 110-NG105 XL 1330

3.28.00.63	1335x13x0,65	14*	1 pc.
3.28.00.67	1335x13x0,65	14*	5 pc.
3.28.00.64	1335x13x0,65	8/12	1 pc.
3.28.00.68	1335x13x0,65	8/12	5 pc.
3.28.00.65	1335x13x0,65	6	1 pc.
3.28.00.69	1335x13x0,65	6	5 pc.
3.28.00.66	1335x13x0,65	18	1 pc.
3.28.00.70	1335x13x0,65	18	5 pc.

* Standard fitting on bandsaws / En dotación estándar en las SIERRA

**VARIABLE PITCH TOOTHING
DENTADO DE PASO VARIABLE**

Tooth pitch
Intervalo del dentado

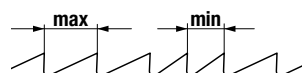

**FIXED PITCH TOOTHING
DENTADO DE PASO FIJO**

1 inch - 1 pulgada
25.4 mm

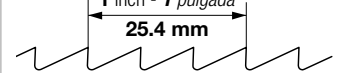

CHOOSE YOUR BLADE! ¡ HELIGE TU HOYA



BI-METAL BAND SAW BLADES IN M42 HSS that combine excellent thermal resistance with high cutting speed. The particular structure of the blade allows it to resist bending, tension and pressure stresses.

HOJAS DE SIERRA DE CINTA BIMETÁLICAS EN M42 HSS que combinan una excelente resistencia térmica con una alta velocidad de corte. La estructura particular de la hoja le permite resistir tensiones de flexión, tensión y presión.



SOLID MATERIALS / MATERIALES SÓLIDOS

BLADE HOJA	780XL - 782XL - 783XL - 782XL 48volt ABS 105 - DCS N G110 - NG 105XL				784XL - NG120 XL - ABS NG120				785XL - NG160 - ABS NG160		
	1335x13x0,65mm				1440x13x0,65mm				1735x13x0,9mm		
TPI (Teeth Per Inch) Dientas para inch	Z18	Z14	Z8/12	Z6	Z18	Z14	Z8/12	Z6	Z14	Z6/10	Z6
Stainless Steel Acero inoxidable	•	•	••	•••	•	•	••	•••	•	••	•••
Cast Iron Hierro fundido	•	••	•••	•••	•	••	•••	•••	•	•••	•••
Iron Hierro	•	•	••••	•••	•	••	••••	•••	•	••••	•••
Aluminum Aluminio	•	•	•••	••••	•	•	•••	••••	•	•••	••••
Plastic Plastico	•	••	•••	••••	•	•	•••	••••	•	•••	••••
Brass Latón	•	•	•••	•••	•	•	•••	•••	•	•••	•••
Copper Cobre	•	•	••••	•••	•	•	••••	•••	•	••••	•••

• Not recommended, •• Acceptable, ••• Good, •••• PRO Level
• No recomendado, •• Admisible, ••• Bueno, •••• Nivel PRO

Z = Teeth Per Inch.
Z = Dientas para inch.



PIPES & PROFILES / TUBERIA Y PERFILES

BLADE HOJA	780XL - 782XL - 783XL - 782XL 48volt ABS 105 - DCS N G110 - NG 105XL				784XL - NG120 XL - ABS NG120				785XL - NG160 - ABS NG160		
	1335x13x0,65mm				1440x13x0,65mm				1735x13x0,9mm		
TPI (Teeth Per Inch) Dientas para inch	Z18	Z14	Z8/12	Z6	Z18	Z14	Z8/12	Z6	Z14	Z6/10	Z6
Stainless Steel Acero inoxidable	••••	•••	••	•	••••	•••	••	•	•••	••	•
Cast Iron Hierro fundido	•••	•••	••	•	•••	•••	••	•	••	•••	•
Iron Hierro	••••	•••	••	•	••••	•••	••	•	••••	•••	•
Aluminum Aluminio	•••	••	••	•	•••	••	••	•	••••	•••	•
Plastic Plastico	•••	••••	•••	•	•••	••••	•••	•	••••	••	•
Brass Latón	•••	••••	•••	•	•••	••••	•••	•	•••	•••	•
Copper Cobre	•••	••••	•••	•	•••	••••	•••	•	••••	•••	•

• Not recommended, •• Acceptable, ••• Good, •••• PRO Level
• No recomendado, •• Admisible, ••• Bueno, •••• Nivel PRO

Z = Teeth Per Inch.
Z = Dientas para inch.



BELT SANDERS RANGE
GAMA LIJADORAS DE BANDA



Bench belt sanders

Lijadoras de banda de banco

PAG. 46



Disk sanders
Lijadoras de disco

PAG. 48



Bench grinders with brake
Esmeriladoras con freno

PAG. 49



Expert line
Linea expert

PAG. 56

BENCH GRINDERS RANGE
GAMA ESMERILADORAS



Tilting belt sanders
Lijadoras de banda inclinable

PAG. 46



Belt/disk combined sanders
Lijadoras combinadas banda/disco

PAG. 48



Linishers
Lijadoras

PAG. 55



Horizontal Belt sanders
Lijadoras de banda horizontal

PAG. 44



Industrial line
Linea Industrial

PAG. 50

Bench grinder/Linishers
Esmeriladora/Lijadora de banda



PAG. 54



Evo
DESIGN

Ecological line
Linea ecológica

PAG. 52



Sharpening Machine
Afiladoras

PAG. 57

577

TECHNICAL FEATURES

- Powerful, reliable and silent induction motor - 4000 Watt
- Three phase motor 2 speeds
- Easy and quick belt replacement
- Sturdy belt tensioning system
- Working table 460 mm x 180 mm
- Belt tensioning device
- 2 operation possibilities: on table and on support

STANDARD EQUIPMENT

- Start-stop switch with anti-reset safety fitted with mushroom button
- Possibility to be connected to an extraction system
- Zirconium Sand belt - grain 60
- Electric control panel
- Adjustable accident prevention guards
- Stainless steel column

CARACTERÍSTICAS TÉCNICAS

- Motore de induccion, potente, silencioso y fiable - 4000 Watt
- Motor trifasico 2 velocidades
- Cambio practico y rapido de la banda
- Sistema robusto de tensión de la banda
- Mesa de trabajo 460 mm x 180 mm
- Dispositivo centrado de la banda
- 2 trabajos: en plano y en apoyo

ÉQUIPEMENT DE SÉRIE

- Interruptor de arranque-parada con sistema de seguridad antiarranque provisto de pulsador fungiforme y de proteccion termica
- Adaptacion para equipo de aspiracion del polvo
- Banda abrasiva de zirconio - grano 60
- Cuadro de mandos electricos
- Protecciones de seguridad regulable
- Base en acero

H 960 CM INCREASED HEIGHT FOR A BETTER AND PRACTICAL USE

H 960 CM ALTURA AUMENTADA PARA USO MEJOR Y MAS PRÁCTICO



**ZIRCONIUM BELT
GRAIN 60
BANDA ABRASIVA DE
ZIRCONIO GRANO 60**



ART.	CODICE CODE	WATT	RPM	m/sec.	mm x mm	mm x mm	mm	Kg
577	8.26.51.30	4.000	1400/2800	15/30	150x2000	460x180	100	90

400 Volt - Hz 50 three-phase motor / Motor trifásico 400 Volt - Hz 50

575/574

TECHNICAL FEATURES

- Powerful, reliable and silent induction motor
- Easy and quick belt replacement
- Sturdy belt tensioning system
- Working table 460 mm x 75 mm
- Belt tensioning device
- 2 operation possibilities: on table and on support

STANDARD EQUIPMENT

- Start-stop switch with anti-reset safety fitted with mushroom button
- Possibility to be connected to an extraction system
- Zirconium Sand belt - grain 60
- Adjustable accident prevention guards
- Stainless steel column

CARACTERÍSTICAS TÉCNICAS

- Motore de induccion, potente, silencioso y fiable
- Cambio practico y rapido de la banda
- Sistema robusto de tensión de la banda
- Mesa de trabajo 460 mm x 75 mm
- Dispositivo centrado de la banda
- 2 trabajos: en plano y en apoyo

ÉQUIPEMENT DE SÉRIE

- Interruptor de arranque-parada con sistema de seguridad antiarranque provisto de pulsador fungiforme y de proteccion termica
- Adaptacion para equipo de aspiracion del polvo
- Banda abrasiva de zirconio - grano 60
- Protecciones de seguridad regulable
- Base en acero

H 960 CM INCREASED HEIGHT FOR A BETTER AND PRACTICAL USE
H 960 CM ALTURA AUMENTADA PARA USO MEJOR Y MAS PRÁCTICO









**ZIRCONIUM BELT
GRAIN 60**
**BANDA ABRASIVA DE
ZIRCONIO GRANO 60**



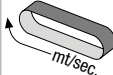
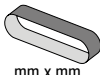
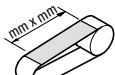

- Rubberized drive pulley
- Polea conductora de goma



- Belt tensioning device
- Dispositivo centrado de la banda

ART.	CODICE CODE	 WATT	 RPM	 m/sec.	 mm x mm	 mm x mm	 mm	 Kg
575	8.26.50.30	3.000 	2800	30	75x2000	460x75	60	79
574	8.26.50.20	2.200 	2800	30	75x2000	460x75	60	79

 230 Volt - Hz 50 single-phase motor / Motor monofásico 230 Volt - Hz 50 •  400 Volt - Hz 50 three-phase motor / Motor trifásico 400 Volt - Hz 50



542B



504B







510



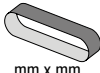
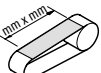
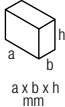

338

BENCH SUPPORT (ON REQUEST)
SOPORTE PARA EL BANCO (BAJO PEDIDO)





ART.	CODE CÓDIGO	 WATT	 RPM	 mm/sec.	 mm x mm	 mm x mm	 a x b x h mm	 Kg
------	----------------	---	--	--	--	---	--	---

BENCH BELT SANDERS / LIJADORAS DE BANDA DE BANCO

510	8.26.60.31	600 	2800	16	100x1000	100X220	620x400x200	15
511	8.26.60.21	550 	2800	16	100x1000	100X220	620x400x200	15



 230 Volt - Hz 50 single-phase motor / Motor monofásico 230 Volt - Hz 50 •  400 Volt - Hz 50 three-phase motor / Motor trifásico 400 Volt - Hz 50

TILTING BELT SANDERS / LIJADORAS DE BANDA INCLINABLE BANCO

542B	8.26.61.33	1000 	1400	27	120x1500	160X410	1200x800x1600	52
ON REQUEST VERSION WITH EXTRACTION SYSTEM (ASP 050) / BAJO PEDIDO: VERSION CON EQUIPO DE ASPIRACIÓN INTEGRADO (ASP 050)								
543B	8.26.61.22	750 	1400	27	120x1500	160X410	1200x800x1600	52
ON REQUEST VERSION WITH EXTRACTION SYSTEM (ASP 050) / BAJO PEDIDO: VERSION CON EQUIPO DE ASPIRACIÓN INTEGRADO (ASP 050)								
504B	8.26.61.32	600/900 	1400/2800	27	120x1500	160X410	1200x800x1600	52
ON REQUEST VERSION WITH EXTRACTION SYSTEM (ASP 050) / BAJO PEDIDO: VERSION CON EQUIPO DE ASPIRACIÓN INTEGRADO (ASP 050)								
507B	8.26.62.32	1350/1600 	1400/2800	30	150x1750	200X500	1200x800x1600	67

ON REQUEST VERSION WITH EXTRACTION SYSTEM (ASP 050) / BAJO PEDIDO: VERSION CON EQUIPO DE ASPIRACIÓN INTEGRADO (ASP 050)

Assembled steel column (included) / Montadas en base de acero (de serie)

 230 Volt - Hz 50 single-phase motor / Motor monofásico 230 Volt - Hz 50 •  400 Volt - Hz 50 three-phase motor / Motor trifásico 400 Volt - Hz 50

TECHNICAL FEATURES

- These products are aimed at industrial machining thanks to their high reliability and sturdiness
- Operation possibilities: on table, on support
- Tilting belt tale unit
- Three phase motor 2 speeds (art. 504B / art. 507B)
- Powerful, reliable and silent induction motors
- Conforming to CE Standards
- Easy and quick belt replacement

STANDARD EQUIPMENT

- Electric control panel (art. 510-511-542B-543B not included)
- Start-stop switch with anti-reset safety fitted with mushroom button
- Adjustable accident prevention guards
- Possibility to be connected to an extraction system
- Sand belt
- Stainless steel column with tool-holder shelf (art. 510-511 not included)

CARACTERÍSTICAS TÉCNICAS

- Productos orientados a trabajos industriales gracias a su gran fiabilidad y robustez
- Trabajos: en plano, en apoyo
- Aparato banda inclinable
- Motor trifásico 2 velocidades (art. 504B / art. 507B)
- Motores de inducción, potentes, silenciosos y fiables
- Conformes con las normativas CE
- Cambio práctico y rápido de la banda

EQUIPEMENTS DE SÉRIE

- Cuadro de mandos eléctricos (excluido ART. 510-511-542B-543B)
- Interruptor de arranque-parada con sistema de seguridad antiarranque provisto de pulsador fungiforme y de protección térmica
- Protecciones de seguridad regulable
- Adaptación para equipo de aspiración del polvo
- Banda abrasiva
- Base en acero con mesa portaobjetos (excepto art. 510-511)



ON REQUEST VERSION WITH EXTRACTION SYSTEM (ASP 050)

BAJO PEDIDO: VERSION CON EQUIPO DE ASPIRACIÓN INTEGRADO (ASP 050)



- Work on table
- Trabajo en plano



- Work on support
- Trabajo en apoyo

TECHNICAL FEATURES

These products are aimed at industrial machining thanks to their high reliability and sturdiness

- Operation possibilities: on table, on support
- Tilting belt and disk tale unit
- Three phase motor 2 speed
- Powerful, reliable and silent induction motors
- Conforming to CE Standards
- Easy and quick belt replacement

STANDARD EQUIPMENT

- Electric control panel
- Start-stop switch with anti-reset safety fitted with mushroom-shaped button
- Adjustable accident prevention guards
- Possibility to be connected to an extraction system
- Sand belt
- Stainless steel column with tool-holder shelf

CARACTERÍSTICAS TÉCNICAS

Productos orientados a trabajos industriales gracias a su gran fiabilidad y robustez

- Trabajos: en plano, en apoyo
- Aparato banda inclinable
- Motor trifásico 2 velocidades
- Motores de inducción, potentes, silenciosos y fiables
- Conformes con las normativas CE
- Cambio práctico y rápido de la banda

EQUIPEMENTS DE SÉRIE

- Cuadro de mandos eléctricos
- Interruptor de arranque-parada con sistema de seguridad antiarranque provisto de pulsador fungiforme y de protección térmica
- Protecciones de seguridad regulable
- Adaptación para equipo de aspiración del polvo
- Banda abrasiva.
- Base en acero con mesa portaobjetos

ON REQUEST VERSION WITH EXTRACTION SYSTEM (ASP 050)

BAJO PEDIDO: VERSION CON EQUIPO DE ASPIRACIÓN INTEGRADO (ASP 050)

539B

525B



ON REQUEST VERSION WITH EXTRACTION SYSTEM (ASP 050)

BAJO PEDIDO: VERSION CON EQUIPO DE ASPIRACIÓN INTEGRADO (ASP 050)

ART.	CODE CÓDIGO	WATT	RPM	mm/sec.	mm x mm	mm x mm	mm	mm	Kg
------	-------------	------	-----	---------	---------	---------	----	----	----

BELT/DISK COMBINED SANDERS / LIJADORAS COMBINADAS BANDA/DISCO

539B	8.28.62.32	1350/1600	1400/2800	30	150X1750	200X500	435X200	400	90°÷135°	81
------	------------	-----------	-----------	----	----------	---------	---------	-----	----------	----

ON REQUEST VERSION WITH EXTRACTION SYSTEM (ASP 050) / BAJO PEDIDO: VERSION CON EQUIPO DE ASPIRACIÓN INTEGRADO (ASP 050)

Assembled steel column (included) / Montadas en base de acero (de serie) - 400 Volt - Hz 50 three-phase motor / Motor trifásico 400 Volt - Hz 50

DISK SANDERS WITH TILTING TABLE / LIJADORAS DE DISCO CON MESA INCLINABLE

525B	8.27.62.32	1350/1600	1400/2800	-	-	-	435X200	400	90°÷135°	52
------	------------	-----------	-----------	---	---	---	---------	-----	----------	----

ON REQUEST VERSION WITH EXTRACTION SYSTEM (ASP 050) / BAJO PEDIDO: VERSION CON EQUIPO DE ASPIRACIÓN INTEGRADO (ASP 050)

Assembled steel column (included) / Montadas en base de acero (de serie) - 400 Volt - Hz 50 three-phase motor / Motor trifásico 400 Volt - Hz 50

BENCH GRINDERS WITH BRAKE ESMERILADORAS CON FRENO

All FEMI bench grinders, both with single phase and three-phase motor, can be delivered (upon request) in version with electronic PCB with brake.

The braking allows the machine to stop smoothly and in the maximum working safety.

Todas las esmeriladoras FEMI sea con motor monofasico que trifasico pueden ser entregadas (bajo pedido) en version con cuadro electrónico y tarjeta de frenado. El frenado garantiza una parada sin tirones en la máxima seguridad de utilización.

TECHNICAL FEATURES

- Control panel complete with electronic braking PCB
- Breaking time from 4 to 8 seconds
- Anti-reset function
- Safety emergency stop button
- On / off indicator light
- Light indicator of voltage presence
- Motor thermal protection
- Motor magnetothermic protection only in 2200 W version (code 7.80.02.93)

CARACTERÍSTICAS TÉCNICAS

- Cuadro de mandos con tarjeta electrónica de frenado
- Tiempo de frenado de 4 hasta 8 segundos
- Función antireset
- Interruptor de emergencia
- Luz indicadora arranque/parada
- Indicador luminoso de presencia de tensión
- Protección térmica del motor
- Protección magnetotérmica del motor en la versión de 2200 W (código 7.80.02.93)



CODE / CÓDIGO	DESCRIPTION / DESCRIPCIÓN	FOR ARTICLES / PARA ARTICULOS
7.80.02.91	BRAKE kit for three phase bench grinders ≥ 450 W Kit para esmeriladoras trifasicas ≥ 450 W	241-241/M - 243-243/M - 245-245/M - 247-247/M - 214-191-191/M - 192-192/M - 196-196/M - 197-197/M - 204 - 294N
7.80.02.92	BRAKE kit for three phase bench grinders 1100/1500 W Kit para esmeriladoras trifasicas 1100/1500 W	143-143/M - 145-145/M-163-163/M- 165-165/M - 209-193-193/M - 194-194/M- 198-198/M-199-199/M-202- and/y EVO models
7.80.02.93	BRAKE kit for three phase bench grinders 2200 W Kit para esmeriladoras trifasicas 2200 W	146-146/M-166-166/M-211-195-195/M- 200-203 and/y EVO models
7.80.02.94	BRAKE kit for single phase bench grinders ≤ 750 W Kit para esmeriladoras monofasicas ≤ 750 W	240-240/M-242-242/M-244-244/M-246-246/M-213 293N

The brake kit must be requested at the time of ordering and cannot be mounted at a later time.

El kit de freno debe solicitarse en el momento de realizar el pedido y no puede montarse posteriormente.

145/M EVO

EVO
DESIGN



243/M

RANGE OF DOUBLE GRINDING WHEEL BENCH GRINDERS

Sturdy and reliable are suitable for roughing-out operations and for removal of material. They can be equipped with grinding wheels of different grits.

GAMA DE ESMERILADORAS DE DOBLE MUELA

Robustas y fiables, están indicadas para operaciones de desbastado de material. Pueden estar provistas de muelas abrasivas con grano diferenciado.



165/M EVO

RANGE OF COMBINED BENCH GRINDERS (GRINDING WHEEL/BRUSH)

In addition to the features of the double grinding wheel, these bench grinders also shave and polish the workpieces. Possibility of assembling various types of grinding wheels and brushes.

GAMA DE ESMERILADORAS COMBINADAS (MUELA/CEPILLO)

A las características de la doble muela se añade la funcionalidad para las operaciones de desbarbado y pulido de piezas. Están adaptadas para el montaje de muelas y cepillos de diferente tipo.



211















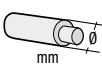
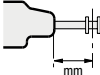























RANGE OF POLISHING MACHINES



Ideal for use at an industrial level in the metal deburring and polishing sector. Possibility of assembling different types or brushes (metal wire or in fabric fibre, etc.).

GAMME DE POLISSEUSES

Ideales para el uso a nivel industrial en el campo del desbarbado y pulido de metales. Están adaptadas para el montaje de cepillos de diferente tipo (filamento metálico o de fibra de tejido, etc.).



ART.	CODE CÓDIGO	 WATT	 Ø mm	 Ø mm	 RPM	 mm	 mm	 a x b x h mm	 Kg	
RANGE OF DOUBLE GRINDING WHEEL BENCH GRINDERS (WITH GRINDING WHEELS) / GAMA DE ESMERILADORAS DE DOBLE MUELA (PROVISTAS DE MUELAS)										
240/M	8.01.31.21	450 	150x20x16	-	2800	-	-	520x210x320	11	
241/M	8.01.32.31	450 	150x20x16	-	2800	-	-	520x210x320	11	
242/M	8.01.33.21	750 	200x25x20	-	2800	-	-	570x290x340	18	
243/M	8.01.34.31	850 	200x25x20	-	2800	-	-	570x290x340	18	
143/M EVO	8.01.35.32	1100 	200x30x20	-	2800	-	-	690x280x360	22	
145/M EVO	8.01.36.32	1500 	250x35x25	-	1400	-	-	720x340x420	32	
146/M	8.01.87.31	2200 	300x40x30	-	1400	-	-	770x470x760	64	
RANGE OF DOUBLE GRINDING WHEEL BENCH GRINDERS (GRINDING WHEELS NOT INCLUDED) / GAMA DE ESMERILADORAS DE DOBLE MUELA (MUELAS NO INCLUIDAS)										
240	8.01.11.21	450 	150x20x16	-	2800	-	-	520x210x320	9	
241	8.01.12.31	450 	150x20x16	-	2800	-	-	520x210x320	9	
242	8.01.13.21	750 	200x25x20	-	2800	-	-	570x290x340	14	
243	8.01.14.31	850 	200x25x20	-	2800	-	-	570x290x340	14	
143 EVO	8.01.15.32	1100 	200x30x20	-	2800	-	-	690x280x360	18	
145 EVO	8.01.16.32	1500 	250x35x25	-	1400	-	-	720x340x420	27	
146	8.01.67.31	2200 	300x40x30	-	1400	-	-	770x470x760	56	
RANGE OF COMBINED BENCH GRINDERS (COMPLETE WITH GRINDING WHEEL - BRUSH NOT INCLUDED) / GAMA DE ESMERILADORAS COMBINADAS (PROVISTAS DE MUELA - SIN CEPILLO)										
244/M	8.02.31.22	450 	150x20x16	150x25x16	2800	16	90	520x210x320	11	
245/M	8.02.32.32	450 	150x20x16	150x25x16	2800	16	90	520x210x320	11	
246/M	8.02.33.21	750 	200x25x20	200x25x16	2800	16	90	570x290x340	16	
247/M	8.02.34.31	850 	200x25x20	200x25x16	2800	16	90	570x290x340	16	
163/M EVO	8.02.35.31	1100 	200x30x20	200x30x20	2800	20	130	690x280x360	24	
165/M EVO	8.02.36.32	1500 	250x35x25	250x30x20	1400	20	135	720x340x420	30	
166/M	8.02.87.31	2200 	300x40x30	300x35x25	1400	25	190	1000x400x760	60	
RANGE OF COMBINED BENCH GRINDERS (WHEEL AND BRUSH NOT INCLUDED) / GAMA DE ESMERILADORAS COMBINADAS (MUELA Y CEPILLO NO INCLUIDOS)										
244	8.02.11.22	450 	150x20x16	150x25x16	2800	16	90	520x210x320	10	
245	8.02.12.32	450 	150x20x16	150x25x16	2800	16	90	520x210x320	10	
246	8.02.13.21	750 	200x25x20	200x25x16	2800	16	90	570x290x340	14	
247	8.02.14.31	850 	200x25x20	200x25x16	2800	16	90	570x290x340	14	
163 EVO	8.02.15.32	1100 	200x30x20	200x30x20	2800	20	130	690x280x360	20	
165 EVO	8.02.16.32	1500 	250x35x25	250x30x20	1400	20	135	720x340x420	22	
166	8.02.67.31	2200 	300x40x30	300x30x25	1400	25	190	1000x400x760	54	
RANGE OF POLISHING MACHINES (BRUSHES NOT INCLUDED) / GAMA DE PULIDORAS (CEPILLOS NO INCLUIDOS)										
213	8.04.13.21	750 	-	200x25x16	2800	16	90	630x240x320	14	
214	8.04.14.31	850 	-	200x25x16	2800	16	90	630x240x320	14	
209 EVO	8.04.15.32	1100 	-	250x30x20	2800	20	135	850x290x390	27	
211	8.04.57.31	2200 	-	300x35x25	2800	25	190	1200x400x760	50	

 230 Volt - Hz 50 single-phase motor / Motor monofásico 230 Volt - Hz 50 •  400 Volt - Hz 50 three-phase motor / Motor trifásico 400 Volt - Hz 50

TECHNICAL FEATURES AND STANDARD EQUIPMENT

These products are suitable for industrial purposes

- These products are suitable for industrial purposes
- 5 years warranty
- Powerful, reliable and silent induction motors
- Integrated safety thermal protection (for motors > 500 W)
- According to CE Standards
- Complete with accident prevention guards and suction fittings
- Switch with anti-reset safety function and padlockable mushroom button
- Standard control panel and cast iron body (ART. 146-146/M-166-166/M-211)

CARACTERÍSTICAS TÉCNICAS Y EQUIPAMIENTO DE SERIE

Productos orientados a trabajos industriales gracias a su gran robustez

- Productos orientados a trabajos industriales gracias a su gran robustez
- 5 años de garantía
- Potentes motores de inducción, fiables y silenciosos
- Protección térmica de seguridad integrada (para motores > 500 W).
- Conformes con las normativas CE
- Provistas de protección para prevención de accidentes y toma para aspiración
- Provistas de interruptor arranque-parada con sistema de seguridad anti-arranque y pulsador fungiforme con posibilidad de bloqueo
- Cuadro de mandos de serie y cuerpo de hierro fundido (ART. 146-146/M-166-166/M-211)

199/M EVO

RANGE OF COMBINED ECOLOGICAL BENCH GRINDERS

In addition to the features of the double grinding wheel, these bench grinders also deburring and polish the workpieces. Possibility of assembling various types of grinding wheels and brushes.

GAMA DE ESMERILADORAS COMBINADAS ECOLÓGICAS

A las características de la doble muela se añade la funcionalidad para operaciones de desbarbado y pulimento de piezas. Están adaptadas para el montaje de muelas y cepillos de diferente tipo.

Evo
DESIGN



192/M

RANGE OF DOUBLE GRINDING WHEEL ECOLOGICAL BENCH GRINDER

Designed with a view to fully comply with workplace health and safety regulations thanks to the extraction system provided, built-into the base. They can be equipped with grinding wheels with different grits.

GAMA DE ESMERILADORAS ECOLÓGICAS DE DOBLE MUELA

Concebidas en el total respeto de las normas de seguridad e higiene del ambiente de trabajo, gracias a la presencia del sistema de aspiración integrado en la base. Pueden estar provistas de muelas abrasivas con grano diferenciado.



203





























RANGE OF ECOLOGICAL POLISHING MACHINES

Designed for industrial polishing operations fully complying with safety and environmental regulations. Possibility of assembling different types of brushes (metal wire, etc.).

GAMA DE PULIDORAS ECOLÓGICAS

Concebidas para operaciones de pulimento industrial con pleno respeto de la seguridad y del ambiente. Están adaptadas para el montaje de cepillos de diferente tipo (filamento metálico, etc.).



ART.	CODE CÓDIGO	 WATT	 Ø mm	 Ø mm	 RPM	 mm	DUST COLLECTOR ASPIRADOR	 Kg	
RANGE OF DOUBLE GRINDING WHEEL ECOLOGICAL BENCH GRINDERS (WHEELS INCLUDED) / GAMA DE ESMERILADORAS ECOLÓGICAS DE DOBLE MUELA (PROVISTAS DE MUELAS)									
191/M	8.00.31.31	450 	150x20x16	-	2800	-	ASP 020	34	
192/M	8.00.33.31	850 	200x25x20	-	2800	-	ASP 020	38	
193/M EVO	8.00.35.32	1100 	200x30x20	-	2800	-	ASP 020	48	
194/M EVO	8.00.39.32	1500 	250x35x25	-	1400	-	ASP 020	55	
195/M	8.00.43.31	2200 	300x40x20	-	1400	-	ASP 020	93	
RANGE OF COMBINED ECOLOGICAL BENCH GRINDERS (GRINDING WHEELS NOT INCLUDED) / GAMA DE ESMERILADORAS ECOLÓGICAS DE DOBLE MUELA (MUELAS NO INCLUIDAS)									
191	8.00.30.31	450 	150x20x16	-	2800	-	ASP 020	29	
192	8.00.32.31	850 	200x25x20	-	2800	-	ASP 020	34	
193 EVO	8.00.34.32	1100 	200x30x20	-	2800	-	ASP 020	39	
194 EVO	8.00.38.32	1500 	250x35x25	-	1400	-	ASP 020	46	
195	8.00.13.31	2200 	300x40x20	-	1400	-	ASP 020	85	
RANGE OF COMBINED ECOLOGICAL BENCH GRINDERS (COMPLETE WITH GRINDING WHEEL - BRUSH NOT INCLUDED) / GAMA DE ESMERILADORAS COMBINADAS ECOLÓGICAS (PROVISTAS DE MUELA - CEPILLO NO INCLUIDOS)									
196/M	8.00.51.32	450 	150x20x16	150x25x16	2800	90	ASP 020	32	
197/M	8.00.53.31	850 	200x25x20	200x25x16	2800	90	ASP 020	37	
198/M EVO	8.00.55.32	1100 	200x30x20	200x30x20	2800	130	ASP 020	47	
199/M EVO	8.00.59.32	1500 	250x35x25	250x30x20	1400	135	ASP 020	52	
200/M	8.00.63.31	2200 	300x40x30	300x35x30	1400	190	ASP 020	91	
RANGE OF COMBINED ECOLOGICAL BENCH GRINDERS (WHEEL AND BRUSH NOT INCLUDED) / GAMA DE ESMERILADORAS COMBINADAS ECOLÓGICAS (MUELA Y CEPILLO NO INCLUIDOS)									
196	8.00.50.32	450 	150x25x16	150x25x16	2800	90	ASP 020	30	
197	8.00.52.31	850 	200x25x20	200x25x16	2800	90	ASP 020	36	
198 EVO	8.00.54.32	1100 	200x30x20	200x30x20	2800	130	ASP 020	41	
199 EVO	8.00.58.32	1500 	250x35x25	250x30x20	1400	135	ASP 020	48	
200	8.00.18.31	2200 	300x40x30	300x35x25	1400	190	ASP 020	87	
RANGE OF ECOLOGICAL POLISHING MACHINES (BRUSHES NOT INCLUDED) / GAMA DE PULIDORAS ECOLÓGICAS (CEPILLOS NO INCLUIDOS)									
204	8.00.71.31	850 	-	200x25x16	2800	90	ASP 020	34	
202 EVO	8.00.72.32	1100 	-	250x30x20	2800	135	ASP 020	49	
203	8.00.29.31	2200 	-	300x35x25	2800	190	ASP 020	98	

 400 Volt - Hz 50 three-phase motor / Motor trifásico 400 Volt - Hz 50

TECHNICAL FEATURES AND STANDARD EQUIPMENT

Products suitable for industrial purposes thanks to their high reliability and sturdiness

- Three-phase electric motor equipped with safety thermal protection (for motors > 500 w)
- Standard integrated dust extractor
- 5 years warranty
- Equipped with removable water reservoir, built-in suction system fit with self-extinguishing filter-bag
- Powerful, reliable and silent induction motors
- According to CE Standards
- Complete with accident prevention guards
- START-STOP switch with anti-reset safety function and padlockable mushroom-shaped button
- Standard control panel and cast iron body (ART.195, 195/M, 200, 200/M, 203)

CARACTERÍSTICAS TÉCNICAS Y EQUIPAMIENTO DE SERIE

Productos orientados a trabajos industriales gracias a su gran fiabilidad y robustez

- Motores eléctricos trifásicos provistos de protección térmica de seguridad (para motores > 500 w)
- Equipo de aspiración integrado de serie
- 5 años de garantía
- Potentes motores de inducción, fiables y silenciosos
- Conformes con las normativas CE
- Provistas de protección para prevención de accidentes y toma para aspiración
- Provistas de interruptor arranque-parada con sistema de seguridad anti-arranque y pulsador fungiforme con posibilidad de bloqueo
- Cuadro de mandos de serie y cuerpo de hierro fundido (ART.146-146/M-166-166/M-211)

294N
293N



- Zirconium belt grain 60 standard fitting
- Banda abrasiva de circonio grano 60 equipo estándar



BENCH GRINDERS/LINISHERS

Sturdy and reliable, this article combines the versatility of the liners to the traditional grinding wheel.

ESMERILADORA/LIJADORA DE BANDA

Robusta y fiable, une a la tradicional muela abrasiva, la versatilidad de las lijadoras de banda.



TECHNICAL FEATURES AND STANDARD EQUIPMENT







Reliable products suitable for industrial purposes owing to the high quality components used.

- 5 years warranty
- Possibility to work both on the table and on the rubber-coated wheel
- Powerful and silent motors equipped with safety thermal protection
- According to CE Standards
- START-STOP switch with anti-reset safety function and padlockable mushroom-shaped button
- Easy and practical belt replacement
- Tilting belt unit
- Adjustable accident prevention guards equipped with suction fitting
- Complete with grinding wheel and sand belt

CARACTERISTICAS TÉCNICAS Y EQUIPAMIENTO DE SERIE

Productos fiables orientados a trabajos industriales gracias a la gran calidad de los componentes utilizados.

- 5 años de garantía
- Trabajos en la mesa de apoyo y sobre la pulea de goma
- Motores potentes y silenciosos provistos de protección térmica de seguridad
- Conformes con las normativas CE
- Provistas de interruptor arranque-paraada con sistema de seguridad anti-arranque y pulsador fungiforme con posibilidad de bloqueo
- Sustitución práctica y rápida de la banda
- Aparato banda inclinable
- Protecciones de seguridad regulables provistas de unión para aspiración
- Provistas de muelas y bandas abrasivas

ART.	CODE CÓDIGO	 WATT	 RPM	 mm x mm	 Ø mm
294N	8.07.10.31	850 	2800	100x1000	200x25x20
293N	8.07.10.21	750 	2800	100x1000	200x25x20

* Column ART.303 available on request / Base Art.303 disponible bajo pedido

 400 Volt - Hz 50 three-phase motor / Motor trifásico 400 Volt - Hz 50

 230 Volt - Hz 50 single-phase motor / Motor monofásico 230 Volt - Hz 50



TECHNICAL FEATURES E STANDARD EQUIPMENT

Reliable products suitable for industrial purposes owing to the high quality components used

- 5 years warranty
- Possibility to work both on the table and on the rubbercoated wheel
- Powerful and silent motors equipped with safety thermal protection
- According to CE Standards
- START-STOP switch with anti-reset safety function and padlockable mushroom-shaped button
- Easy and practical belt replacement
- Tilting belt unit
- Adjustable accident prevention guards equipped with suction fitting
- Complete with grinding wheels and sand belts

CARACTERÍSTICAS TÉCNICAS Y

EQUIPAMIENTO DE SERIE

Productos fiables orientados a trabajos industriales gracias a la gran calidad de los componentes utilizados

- 5 años de garantía
- Trabajos en la mesa de apoyo y sobre la polea de goma
- Motores potentes y silenciosos provistos de protección térmica de seguridad
- Conformes con las normativas CE
- Provistas de interruptor arranque-parada con sistema de seguridad anti-arranque y pulsador fungiforme con posibilidad de bloqueo
- Sustitución práctica y rápida de la banda
- Aparato banda inclinable
- Protecciones de seguridad regulables provistas de unión para aspiración
- Provistas de muelas y bandas abrasivas

296 EVO

BENCH GRINDERS/LINISHERS

Sturdy and reliable, this article combines the versatility of the linishers to the traditional grinding wheel.

ESMERILADORA/LIJADORA DE BANDA

Robusta y fiable, une a la tradicional muela abrasiva, la versatilidad de las lijadoras de banda.



298 EVO

LINISHERS

Equipped with different grits belt equipment and mobile surrounding guards. Its ideal use is for shaving operations and foundry casting treatment owing to the high peripheral speed of the belt.

LIJADORA DE BANDA

Provista de banda de lija de grano diferenciado, está equipada con protecciones integrales móviles. Es sumamente adecuada para las operaciones de desbarbado y tratamiento de fundiciones gracias a la elevada velocidad periférica de la banda.



303

**COLUMN (ON REQUEST)
BASE (BAJO PEDIDO)**

ART.	CODE CÒDIGO	WATT	RPM	mm x mm	Ø mm
BENCH GRINDER/LINISHERS / ESMERILADORA/LIJADORA DE BANDA					
296* EVO	8.06.10.32	1100	2800	50x2200	200X25x20
LINISHER / LIJADORA DE BANDA					
298* EVO	8.06.11.31	1100	2800	50x2200	-

* Column ART.303 available on request / Base Art.303 disponible bajo pedido
 400 Volt - Hz 50 three-phase motor / Motor trifásico 400 Volt - Hz 50



404

BENCH GRINDERS DOUBLE WHEEL Ø 150
ESMERILADORAS DOBLE MUELA Ø 150



405

BENCH GRINDERS DOUBLE WHEEL Ø 200
ESMERILADORAS DOBLE MUELA Ø 200



424

COMBINED BENCH GRINDERS Ø 150
ESMERILADORAS COMBINADAS Ø 150



425

COMBINED BENCH GRINDERS Ø 200-150
ESMERILADORAS COMBINADAS Ø 200-150











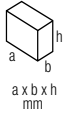

TECHNICAL FEATURES E STANDARD EQUIPMENT

- Reliable and silent induction motors
- Equipped with accident prevention guards and suction fitting (not contemplated for ART. 404-424)
- Equipped with START-STOP switch with anti-reset safety function
- Complete with grinding wheels and steel brushes (ART. 424 and 425)
- Possibility of being applied to the steel column ART. 303

CARACTERISTICAS TÉCNICAS Y EQUIPAMIENTO DE SERIE

- Motores de inducción, fiables y silenciosos
- Provistas de protecciones para prevención de accidentes y unión para aspiración (no previsto para ART. 404 y 424)
- Provistas de interruptor arranque-parada con sistema de seguridad anti-arranque
- Equipadas con muelas abrasivas y cepillos de acero (ART. 424 y 425)
- Adaptadas para aplicaciones sobre base de acero ART. 303

ART.	CODE CÒDIGO	 WATT	 Ø mm	 Ø mm	 RPM	 a x b x h mm	 Kg
404	8.01.54.20	370 	150x20x16	-	2800	520x210x320	10
405	8.01.56.20	500 	200x20x16	-	2800	570x290x340	15
424	8.02.54.20	370 	150x20x16	150x20x16	2800	520x210x320	12
425	8.02.56.20	500 	200x20x16	150x20x16	2800	520x290x340	15

 230 Volt - Hz 50 single-phase motor / Motor monofásico 230 Volt - Hz 50

182 PLUS

ART.	CODE / CÓDIGO
182 PLUS	8.13.23.21



COMBINED SHARPENING MACHINE

Machine equipped with two grinding wheels that rotate at differentiated speed; grinding wheel suitable for all the common grinding and shaving operations; slow-turning water bath sharpening wheel for sharpening scissors, knives, chisels and blades in general.

TECHNICAL FEATURES

- Reliable and silent induction motors
- Conforming to CE Standards

STANDARD EQUIPMENT

- Accident prevention guards
- Wheel wiper brush
- High quality white corundum sharpening unit with large grinding wheel
- Sharpening and grinding wheels

AFILADORA COMBINADA

Máquina provista de dos muelas coaxiales giratorias de velocidad diferenciada; muela esmeriladora apta para todas las operaciones de esmerilado y desbarbado; muela afiladora de vueltas lentas en baño de agua que permite afilar tijeras, cuchillos, cinceles y todo tipo de hoja en general.

CARACTERÍSTICAS TÉCNICAS

- Motores de inducción, fiables y silenciosos
- Conforme con las normativas CE

EQUIPAMIENTO DE SERIE

- Protecciones para prevención de accidentes
- Cepillo limpiamuela
- Grupo de afilado con muela de grandes dimensiones de corindón blanco fino
- Muela esmeriladora



500 WATT 150x20x16 2800 RPM 180x30x20 200 RPM 400x255x250 Kg 10

230 Volt - Hz 50 single-phase motor
Motor monofásico 230 Volt - Hz 50

177

ART.	CODE / CÓDIGO
177	8.13.22.21



WATER-OPERATED SHARPENING MACHINE

Single-wheel professional sharpening machine with ABS shockproof structure equipped with high quality white corundum wheel partially soaked in water for the perfect sharpening of all types of blades and cutting tools.

TECHNICAL FEATURES E STANDARD EQUIPMENT

- Reliable and silent induction motor
- High quality white corundum sharpening wheel
- Double safety insulation

AFILADORA DE AGUA

Afiladora profesional mono-muela con estructura de ABS antichoque provista de muela de corindón fino blanco parcialmente sumergido en agua para garantizar el perfecto afilado de todos los tipos de hojas y herramientas de corte.

CARACTERÍSTICAS TÉCNICAS Y EQUIPAMIENTO DE SERIE

- Motor de inducción, fiable y silencioso
- Muela afiladora de corindón blanco fino
- Doble aislamiento de seguridad



150 WATT 200x40x20 120 RPM 425x275x270 Kg 6,5

230 Volt - Hz 50 single-phase motor
Motor monofásico 230 Volt - Hz 50

COLUMNS / BASES



303



308N



338

TECHNICAL FEATURES

Sturdy column in pressed and shaped steel fitter with removable water reservoir for tool cooling.

CARACTERÍSTICAS TÉCNICAS

Robusta base de acero estampado y perfilado provista de recipiente para agua, desmontable para el enfriamiento de las herramientas.

ART.	CODE / CÓDIGO	FOR ARTICLES / PARA ARTICULOS
303	7.13.35.06	143-143/M-145-145/M-163-163/M-165-165/M-208-209-213-214-240-240M - 241-241/M-242-242/M-243-243/M-244-244/M-245-245/M-246-246/M - 247-247/M-282-296-298-404-405-424-425
303+ASP020	7.13.35.97	+ EVO models 293N-294N
304	7.13.35.07	
304+ASP020	7.13.35.98	146-146/M-166-166/M-211
338	7.13.36.50	510-511
308N	7.13.35.83	All belt sanders - Todos las lijadoras



CONTROL PANEL - ULTRA-LOW TENSION (24 V) / CUADRO DE MANDOS - DE BAJISIMA TENSIÓN (24 V)

CODE / CÓDIGO	DESCRIPTION / DESCRIPCIÓN
7.80.02.27	For bench grinders WATT 450-850 / Para esmeriladoras WATT 450-850
7.80.02.30	For bench grinders WATT 1100-1500 / Para esmeriladoras WATT 1100-1500
7.80.02.31	For bench grinders WATT 2200 / Para esmeriladoras WATT 2200
7.80.02.32	For 1-speed belt sanders / Para lijadoras 1 velocidad
7.80.02.29	For 2-speed belt sanders / Para lijadoras 2 velocidades

The control panel is equipped with a 24-Volt transformer, magnetothermal circuit breaker, emergency mushroom-shaped button, start/stop buttons and power LED. IP 55 insulation class. Complete with support for assembly operations. Particularly suitable for technical schools, public bodies and industries for absolute safety.

Cuadro de mandos provisto de transformador 24 V, interruptor magnetotérmico, pulsador fungiforme de emergencia, pulsadores de marcha/parada y testigo luminoso de tensión. Grado de protección IP 55. Provisto de soporte para el montaje. Especialmente adecuado para institutos técnicos, entes estatales e industriales por la absoluta seguridad.









CONTROL PANEL / CUADRO DE MANDOS



CODE / CÓDIGO	DESCRIPTION / DESCRIPCIÓN
7.80.02.07	Control panel for bench grinders WATT 450-750 Cuadro de mandos para esmeriladoras WATT 450-700
7.80.02.08	Control panel for bench grinders WATT 450-850 Cuadro de mandos para esmeriladoras WATT 450-850
7.80.02.09	Control panel for bench grinders WATT 1100-1500 Cuadro de mandos para esmeriladoras WATT 1100-1500
7.80.02.13	For belt sanders / Para lijadoras 510 - 542B
7.80.02.16	For belt sanders / Para lijadoras 511 - 543B

Control panel equipped with magnetothermal circuit breaker and emergency mushroom-shaped button. Insulation class. Complete with support for assembly operations.

Cuadro de mandos provisto de interruptor magnetotérmico y pulsador fungiforme de emergencia. Grado de protección IP 55. Provisto de soporte para el montaje.

ART.	CODE CÒDIGO	 WATT	 M³/h	 press. mm H ₂ O	 Ø mm	FOR ARTICLES / PARA ARTICULOS
CENTRIFUGAL DUST COLLECTORS / ASPIRADORES CENTRIFUGOS						
ASP 020	7.11.20.10	150 	410	95	35	143-143/M-145-145/M-146-146/M-163-163/M-165-165/M-166-166/M - 208-209-211-213-214-240-240/M-241-241/M-242-242/M-243-243/M - 244-244/M-245-245/M-246-246/M-247-247/M- 282-296-298-510-511 + EVO models
	7.11.20.51*					
ASP 020	7.11.20.57	150 	410	95	35	577 - 575
	7.11.20.58		410	95	35	574
ASP 050	7.11.20.12	370 	980	120	90	542B-543B-504B-505B-507B-522B-525B-534B-535B
	7.11.20.52*					536B-537B-539B-502-503-504

* Delivered installed on the column (column non included) - Provistos de montaje en la base de la máquina (base no incluida)

CENTRIFUGAL DUST COLLECTORS*

Suitable for extracting metallic dust coming from the grinding, sanding and polishing processes. Complete with coupling flange for being assembled onto columns 303, 303E and 304 (bench grinders) and 308/N (belt sanders). Fitted with filter bag made of self-extinguishing fabric. Version ASP 020 is provided with 2 suction air inlets for pipes Ø 35 (450 W - 750 W - 1100 W - 1500 W bench grinders). Inlets are also available for pipes with Ø 50 (2200 W bench grinders) and Ø 60 (polishing machines). All the suction inlets in the ASP 050 version are for pipes Ø 90 (belt sanders)

*THREE-PHASE 400 VOLT - STANDARD / SINGLE PHASE 230 VOLT - ON REQUEST



ASPIRADORES CENTRÍFUGOS*

Aptos para la aspiración y la recogida de polvos metálicos provenientes de trabajos de esmerilado, lijado y pulido. Provistos de brida de acoplamiento para el montaje sobre las bases 303, 303E y 304 (esmeriladoras) y 308/N (lijadoras). Con bolsa filtro recogedor de hebra autoextinguible. En la versión ASP. 020 están incluidas dos bocas de aspiración para tubos Ø 35 (esmeriladoras 450 W - 750 W - 1100 W - 1500 W). También están disponibles bocas para tubos Ø 50 (esmeriladoras 2200 W) y Ø 60 (pulidoras). En la versión ASP 050 las bocas de aspiración son todas para tubo de Ø 90 (lijadoras)

*TRIFÁSICO 400 VOLT - DE SERIE / MONOFÁSICO 230 VOLT - BAJO PEDIDO

DUST FILTER-BAGS. IN SELF-EXTINGUISHING FABRIC
BOLSAS-FILTRO DE RECOGIDA DEL POLVO. DE MATERIAL AUTOEXTINGUIBLE

CODE CÒDIGO	FOR ARTICLES PARA ARTICULOS
5.07.32.05	ASP 020
5.07.32.06	ASP 050



ADAPTERS
BOCAS ASPIRACIÓN

CODE CÒDIGO	FOR PIPES / PARA TUBOS Ø MM	FOR ARTICLES PARA ARTICULOS
5.24.13.28	35	ASP 020
5.24.13.20	50	ASP 020
5.24.13.21	60	ASP 020





ALUMINIUM PIPES FOR DUST COLLECTORS
TUBOS DE ALUMINIO PARA ASPIRADORES

CODE CÒDIGO	Ø mm	MINIMUM ORDER (MT) PEDIDO MÍNIMO (MT)
1.95.35.01	35	3
1.95.50.01	50	3
1.95.60.01	60	3
1.95.90.02	90	3
1.95.99.02	100	3







WHEELS, SAND BELT AND BRUSHES FOR INDUSTRIAL RANGE / MUELAS, BANDAS ABRASIVAS Y CEPILLOS PARA SERIE INDUSTRIAL

CODE CÓDIGO	 Ø mm	 Ø mm	 mm x mm	GRAIN GRANO	PIECES NR. PIEZAS N°	FOR ART. PARA ART.
IN SINGLE PACK / EN PAQUETE UNITAR						
3.22.99.23	150x20x16/12*/12,7*		-	36	1	191-191/M-196-196/M-240-240/M-241-241/M-244-244/M-245-245/M
3.22.99.24	150x20x16/12*/12,7*		-	60	1	191-191/M-196-196/M-240-240/M-241-241/M-244-244/M-245-245/M
3.22.99.30	200x25x20		-	36	1	192-192/M-197-197/M-242-242/M-243-243/M-246-246/M-247-247/M-296-293N-294N
3.22.99.31	200x25x20		-	60	1	192-192/M-197-197/M-242-242/M-243-243/M-246-246/M-247-247/M-296-293N-294N
3.22.99.32	200x30x20		-	36	1	143-143/M-163-163/M-193-193/M-198-198/M
3.22.99.33	200x30x20		-	60	1	143-143/M-163-163/M-193-193/M-198-198/M
3.22.12.61	250x35x25		-	36	1	145-145/M-165-165/M-194-194/M-199-199/M
3.22.13.59	250x35x25		-	60	1	145-145/M-165-165/M-194-194/M-199-199/M
3.22.11.75	300x40x30		-	24	1	146-146/M-166-166/M-195-195/M-200-200/M
3.22.12.74	300x40x30		-	46	1	146-146/M-166-166/M-195-195/M-200-200/M
3.23.99.40	-	200x25x16	-	60	1	246 - 246/M - 247 - 247/M - 213 - 214 - 167 - 197/M - 204
3.23.99.41	-	200x30x20	-	60	1	163 EVO - 163 M EVO - 198 EVO - 198 M EVO
3.23.99.42	-	250x30x20	-	60	1	165 EVO - 165 M EVO - 209 EVO - 199 EVO - 199/M EVO - 202 EVO
3.23.99.43	-	300x35x25	-	60	1	166 - 166/M - 211 - 200 - 200/M - 203
SAND BELTS / BANDAS ABRASIVAS EN PAQUETE ESTÁNDAR						
3.23.99.17	-		50x2200	40	10	296-298
3.23.99.18	-		50x2200	60	10	296-298
3.23.99.19	-		50x2200	80	10	296-298

*With reduction bushing included in the packaging / *Con reducciones incluidas

WHEELS, BRUSHES AND SANDING BELTS PROFESSIONAL RANGE / MUELAS, CEPILLOS Y BANDAS ABRASIVAS PARA SERIE PROFESIONAL

CODE CÓDIGO	 Ø mm	 Ø mm	 Ø mm	 mm x mm	GRAIN GRANO	PIECES NR. PIEZAS N°	FOR ART. PARA ART.
3.22.99.23	150x20x16/12*/12,7*	-	-	-	36	1	404-424-182PLUS
3.22.99.24	150x20x16/12*/12,7*	-	-	-	60	1	404-424-182PLUS
3.22.99.25	200x20x16	-	-	-	36	1	405 - 425
3.22.99.26	200x20x16	-	-	-	60	1	405 - 425
3.22.99.28	-	180x30x20	-	-	150	1	182 PLUS
3.22.99.27	-	200x40x20	-	-	150	1	177
3.23.99.35	-	-	150x20x16	-	-	1	424-425

*With reduction bushing included in the packaging / *Con reducciones incluidas

WHEELS, BRUSHES AND SANDING BELTS

Disk grinding wheels either made of gray corundum (carborundum) and ceramics binder (bench grinders) or of high quality white corundum and glazed ceramics binder (sharpening machines). Corundum sand belts, high resistance reinforced fabric support and ground joints for greater smoothness. Grinding wheels and belts available in different grits: the higher the number the finer the grit (suitable for deburring and finishing), whereas the lower the number the rougher the grit (suitable for grinding and roughing-out).

MUELAS, CEPILLOS Y BANDAS

Muelas de disco de corindón gris (carburo de silicio) y aglutinante cerámico (esmeriladoras) o bien de corindón fino blanco y aglutinante cerámico vitrificado (afiladoras).

Bandas abrasivas de corindón, soporte de tela reforzada de gran resistencia,

Uniones lijadas para garantizar un mayor deslizamiento. Muelas y bandas disponibles en diferentes granos: a un número más alto corresponde un grano más fino (ideal para desbarbados y acabados), mientras que a un número más bajo corresponde un grano más grueso (ideal para esmerilado y desbastado).



SANDING BELTS - STANDARD PACK
BANDAS ABRASIVAS - EN PAQUETE ESTÁNDAR

CODE CÓDIGO	 mm x mm	GRAIN GRANO	PIECES NR. PIEZAS N°	FOR ART. PARA ART.
3.23.99.20	100x1000	50	10	510 - 511-293N-294N
3.23.99.21	100x1000	80	10	
3.23.99.22	120x1500	40	10	542B - 543B-504B - 534B - 535B - 536B - 502 - 503 - 504
3.23.99.23	120x1500	60	10	
3.23.99.24	120x1500	80	10	
3.23.99.25	150x1750	40	10	
3.23.99.26	150x1750	60	10	505B - 507B - 537B - 539B
3.23.99.27	150x1750	80	10	

SANDING BELTS - STANDARD PACK
BANDAS ABRASIVAS - EN PAQUETE ESTÁNDAR

CODE CÓDIGO	 mm x mm	GRAIN GRANO	PIECES NR. PIEZAS N°	FOR ART. PARA ART.
3.23.99.36	100x1000	60	3	293N - 294N
3.23.99.37	75x2000	60	3	574 - 575
3.23.99.38	150x2000	60	3	577

SANDING DISK - STANDARD PACK / DISCOS ABRASIVAS - EN PAQUETE ESTÁNDAR

CODE CÓDIGO		GRAIN GRANO	PIECES NR. PIEZAS N°	FOR ART. PARA ART.
3.23.99.31	Ø 400 mm	40	10	537B - 539B - 525B
3.23.99.32	Ø 400 mm	60	10	
3.23.99.33	Ø 400 mm	80	10	

ADAPTERS FOR WELCRO DISK / ADAPTADORES PARA DISCOS VELCRO

3.23.75.09	For disk - Para discos Ø 350 mm
3.23.75.10	For disk - Para discos Ø 400 mm



GREAT PERFORMANCES LINE / LÍNEA DE ALTAS PRESTACIONES Ø 305

305 PRO

168x78



PAG. 68

Global versatility for the everyday job
Versatilidad total para el trabajo diario

305S

170x78



PAG. 70

The strength for tradition
La fuerza por tradición

999 EVO

165x100



PAG. 67

Energy and power in 18 kgs
Energía y potencia en 18 kg



ALU LINE / LÍNEA DE ALU Ø 305

XXX EVO ALU

170x70



Once more, one step ahead!
Otra vez, otro paso hacia el futuro!

PAG. 73

GREAT PERFORMANCES LINE / LÍNEA DE ALTAS PRESTACIONES Ø 305

911 EVO

165x100



PAG. 66

Outstanding leading performances
Prestaciones líderes

XXX EVO

170x70

PAG. 65



VIDEO

Once more, one step ahead!
Otra vez, otro paso hacia el futuro!



VIDEO

1050 3D

305x90



PAG. 64



PORTABLE LINE / LÍNEA DE FÁCIL TRANSPORTE Ø 250÷280

732

L MAX H MAX

162x78



PAG. 72

The indispensable
La indispensable

733

L MAX H MAX

162x75



PAG. 72

Silent and reliable
Silenciosa y fiable

280S

150x70



PAG. 71

Really unique
Realmente única

XPANDER

Parquet cutter
Corta parquet

PAG. 69



VIDEO

IB500

Edge bander
Encoladora de cantos



PAG. 75



VIDEO

1050 3D

ART.	CODE / CÓDIGO
1050 3D	8.43.50.27

PATENTED

TECHNICAL FEATURES

Three combined functions:
Mitresaw with upper table, sliding compound mitresaw, bench circular saw.

- Maximum cutting capacity on the upper table: 60 mm! (only with blade protection mounted)
- Cutting angles 60° right and 50° left with automatic locking device
 0° - 15° - 22,50° - 30° - 45°
- Patented change function system from mitresaw to circular saw easy and quick
- Telescopic sliding bars Ø 30 mm

STANDARD EQUIPMENT

- Side extensions for big cuttings
- Vertical clamp for clamping of cutting material
- Blade protection for cutting on the upper table
- Key set / wood pusher

CARACTERÍSTICAS TÉCNICAS

Tres funciones combinadas: Corte inferior, corte superior y corte longitudinal telescópico

- Corte en la mesa superior maxima: 60 mm! (sólo con protección de disco montada)
- Ángulo de corte 60° derecha y 50° izquierda, con dispositivo de bloqueo automático a
 0° - 15° - 22,5° - 30° - 45°
- Sistema patentado de cambio de función de tronzadora a tronzadora de disco, rápido y fácil
- Barras de desplazamiento radial Ø 30 mm

EQUIPAMIENTO DE SERIE

- Extensiones laterales para cortes de grandes dimensiones
- Morzada vertical para el bloqueo de la pieza
- Protección de disco para cortes en la mesa superior
- Llaves en dotación / accesorio para empujar la madera



Ø 305 mm

LASER

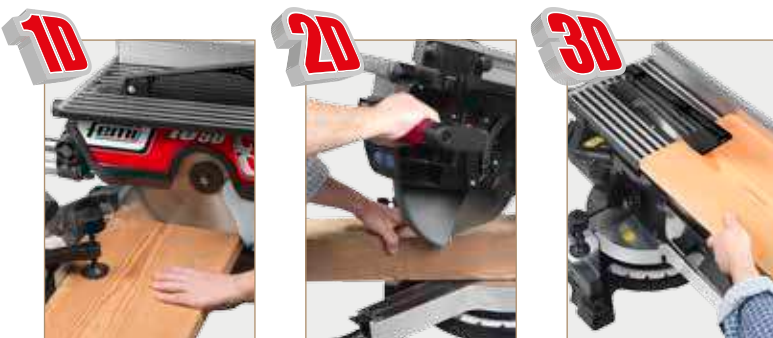

CUTTING CAPACITY / CAPACIDAD DE CORTE

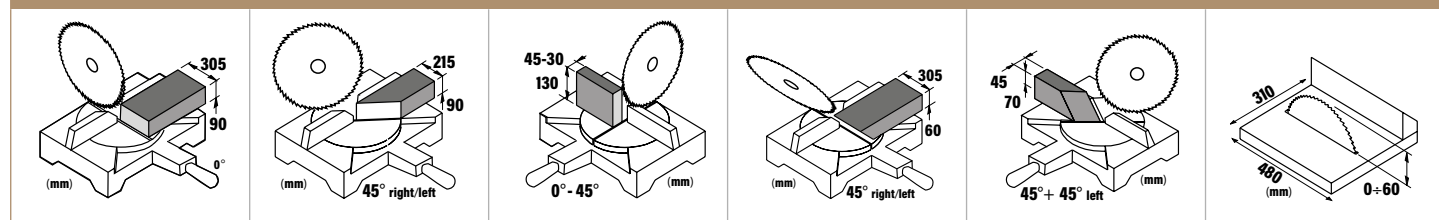

1800 W	3600 RPM	D305 -d30	990x650x460	28 Kg	90 mm	305 mm

230 Volt - Hz 50 single-phase motor / Motor monofásico 230 Volt - Hz 50

XXX EVO

ART.	CODE / CÓDIGO
XXX EVO	8.43.60.45



TECHNICAL FEATURES

- Movements on bearings of the turning table, head and joint
- Powerful 1500 Watt induction motor
- Piece support with sliding kit (INCLUDED)
- New T.P.S. (Three Positions System) handle (Patented)
- Micrometric adjustment of the upper working table

STANDARD EQUIPMENT

- Chrome coated blade with Widia inserts and noise dampening-slots with key set.
- Vertical clamp
- Adjustable bar stop-rod for mass-produced cuts.
- Supplementary protection and wood pusher
- Sliding Kit

CARACTERÍSTICAS TÉCNICAS

- Movimientos sobre cojinetes de la mesa giratoria, cabeza y articulación
- Motor de inducción silencioso y potente 1500 Watt
- Apoyo de la pieza con kit deslize incluido
- Nueva empuñadura TPS (Three Position System) (Patentado)
- Regulación micrométrica de la mesa superior de trabajo

EQUIPAMIENTO DE SERIE

- Hoja con inserciones en Widia cromada y con hendiduras silenciadoras con liaves
- Mordaza vertical
- Varilla de sujeción de la barra para realizar cortes en serie
- Protección adicional y dispositivo de empuje madera
- Kit de deslizamiento



Ø 305 mm

Piece support with sliding kit (INCLUDED)
Apoyo de la pieza con kit de deslizamiento incluido

PATENTED

T.P.S. THREE POSITIONS SYSTEM



CUTTING CAPACITY / CAPACIDAD DE CORTE

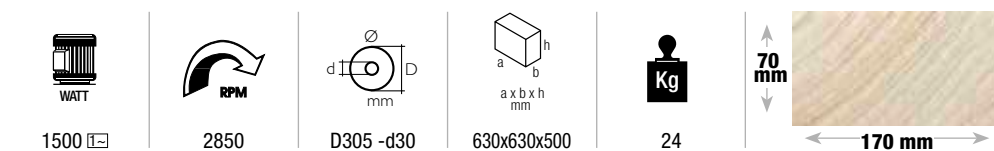
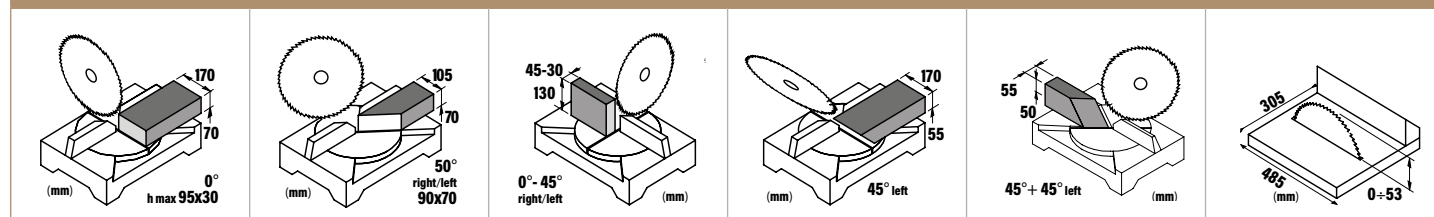

230 Volt - Hz 50 single-phase motor / Motor monofásico 230 Volt - Hz 50

911 EVO

ART.	CODE / CÓDIGO
911 evo	8.43.60.47

TECHNICAL FEATURES

- Large upper working table (305x503 mm) with micrometric height adjustment
- Aluminium section upper table straightedge adjustable in two positions and with dual front and rear fixing system
- Silent and more powerful 1600 Watt induction motor with thermal protection
- Silent and reliable "POLY-V" belt transmission
- Base with integrated release lever protection

STANDARD EQUIPMENT

- Chromed blade with Widia inserts
- Additional sliding pieces support
- Adjustable bar stop-rod for mass-produced cuts
- Supplementary protection and wood pusher and key set
- Vertical clamp

CARACTERÍSTICAS TÉCNICAS

- Mesa de trabajo superior de grandes dimensiones (305x503 mm) con regulación micrométrica de la altura
- Regla superior de perfil de aluminio con regulación en 2 posiciones y con sistema de fijación doble (delantera y trasera)
- Motor de inducción silencioso y potente 1600 W con protección térmica
- Transmisión de correa "POLY-V" silenciosa y segura
- Base con protección integrada de la palanca para el desbloqueo

EQUIPAMIENTO DE SERIE

- Disco con inserciones en Widia cromada
- Varilla de sujeción de la barra para realizar cortes en serie
- Llaves en dotación
- Protección adicional y dispositivo de empuje madera
- Kit de deslizamiento
- Mordaza vertical

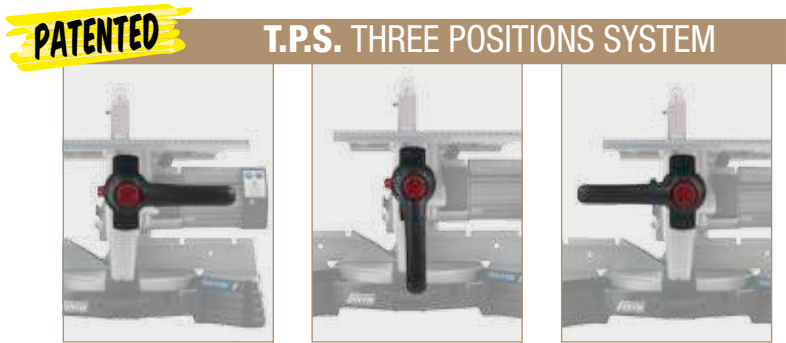

CUTTING CAPACITY / CAPACIDAD DE CORTE

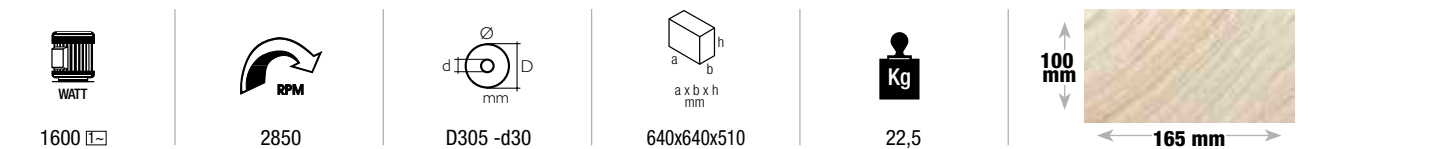
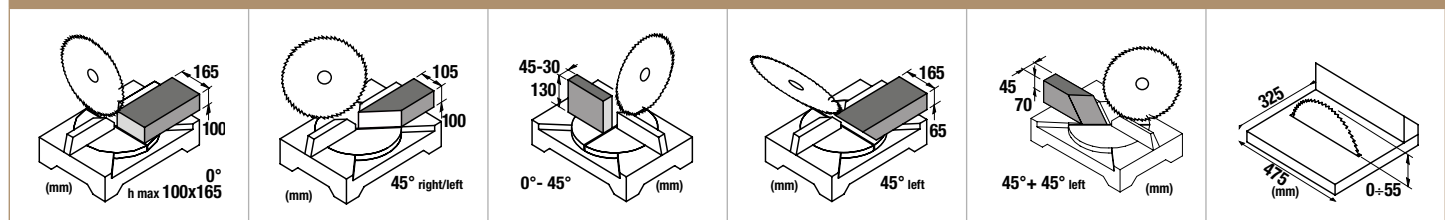

☑ 230 Volt - Hz 50 single-phase motor / Motor monofásico 230 Volt - Hz 50

999 EVO

ART.	CODE / CÓDIGO
999 EVO	8.43.60.43

TECHNICAL FEATURES

- Aluminium section upper table straightedge adjustable in two positions and with dual front and rear fixing system
- Large upper working table (305x503 mm) with micrometric height adjustment
- Electronic control of the anti-reset safety function
- Base with integrated release lever protection with mechanical end-run limit
- Double mitre cut 45°+45° left

STANDARD EQUIPMENT

- Chromed blade with Widia inserts
- Pieces support with sliding KIT (included)
- Adjustable bar stop-rod for mass-produced cuts
- Supplementary protection and wood pusher
- Vertical clamp

CARACTERÍSTICAS TÉCNICAS

- Regla superior de perfil de aluminio con regulación en 2 posiciones y con sistema de fijación doble (delantera y trasera)
- Mesa de trabajo superior de grandes dimensiones (305x503 mm) con regulación micrométrica de la altura
- Control electrónico del sistema de seguridad anti-arranque
- Base con protección integrada de la palanca para el desbloqueo con fin de carrera
- Corte combinado 45°+45° izquierda

EQUIPAMIENTO DE SERIE

- Disco cromado con inserciones en Widia
- Apoyo de la pieza con kit e deslizamiento incluido
- Varilla de sujeción de la barra para realizar cortes en serie
- Protección adicional y accesorio para empujar la madera
- Mordaza vertical



Powerful universal motor 1700 watt

Potente motor universal 1700 W

Ø 305 mm

Piece support with sliding kit (INCLUDED)
Apoyo de la pieza con kit de deslizamiento incluido

PATENTED

T.P.S. THREE POSITIONS SYSTEM



CUTTING CAPACITY / CAPACIDAD DE CORTE

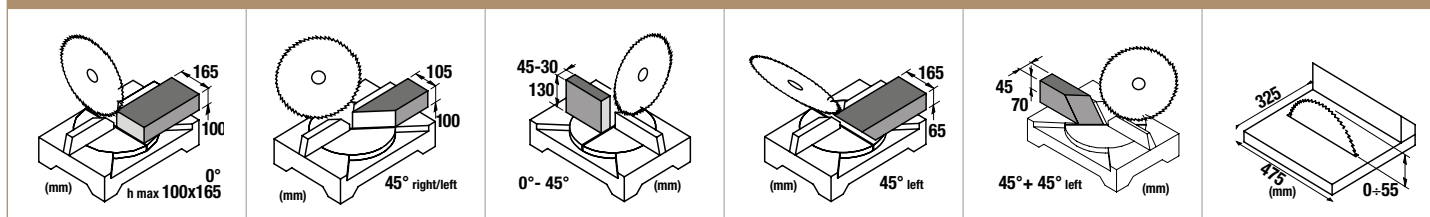

1700



4200



D305 -d30



640x640x510



18



165 mm

230 Volt - Hz 50 single-phase motor / Motor monofásico 230 Volt - Hz 50

305 PRO

ART.	CODE / CÓDIGO
305 PRO	8.43.60.44

TECHNICAL FEATURES

- Powerful 1300 Watt induction motor
- Base suitable for Sliding Kit (OPTIONAL)
- T.P.S. (Three Positions System) handle (Patented)
- Upper table in aluminium extrusion with lateral extension (OPTIONAL - see pag 73)
- Base with integrated release lever protection with mechanical end stroke

STANDARD EQUIPMENT

- Chrome coated blade with Widia inserts and noise dampening-slots with key set
- Vertical clamp
- Supplementary protection and wood pusher

CARACTERÍSTICAS TÉCNICAS

- Potente motor de inducción 1300 W
- Mesa de trabajo con predisposición para el kit de deslizamiento (OPCIONAL)
- Empunadura TPS (Three Positions System) (Patentado)
- Mesa superior de trabajo de extrusión con extensión lateral (OPCIONAL - Ver página 73)
- Base con y protección integrada de la palanca para el desbloqueo con fin de carera

EQUIPAMIENTO DE SERIE

- Hoja con inserciones en Widia cromada y con hendiduras silenciadoras con liaves
- Mordaza vertical
- Protección adicional y dispositivo de empuje madera



PATENTED

T.P.S. THREE POSITIONS SYSTEM

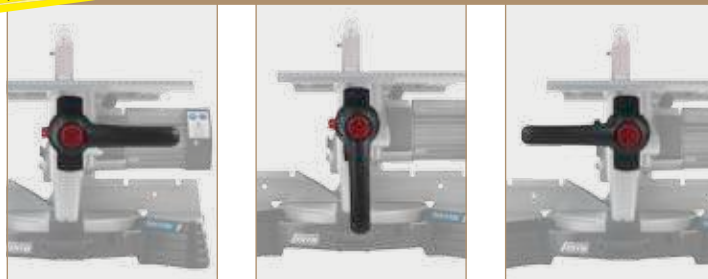

CUTTING CAPACITY / CAPACIDAD DE CORTE

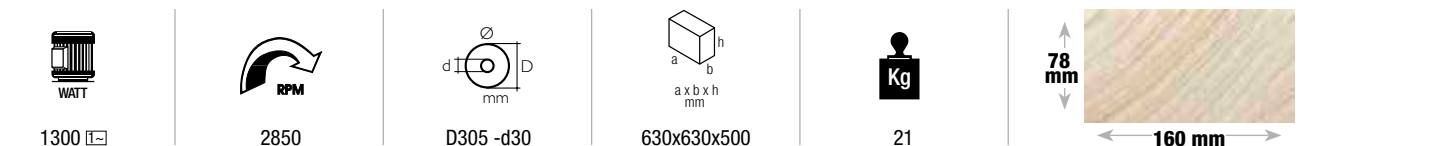
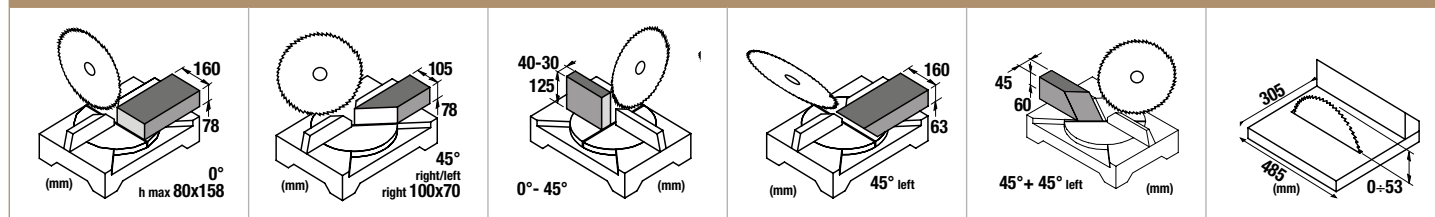

□ 230 Volt - Hz 50 single-phase motor / Motor monofásico 230 Volt - Hz 50

X PANDER



ART.	CODE / CÓDIGO
XPANDER	7.07.50.76



VIDEO

TECHNICAL FEATURES

- Made in aluminium, it increases the cutting capacity up to 30%
- It allows compound cuts up to 48° to compensate walls out of square
- Designed for the application of both the horizontal clamp and the vertical clamp
- Easy and fast assembling on the machine thanks to 2 fast fixing points
- Exclusive and patented design

CARACTERÍSTICAS TÉCNICAS

- En aluminio, mayor capacidad de corte hasta el 30%
- Ángulo de corte regulable hasta 48° para el ajuste de las paredes exteriores
- Predisposición para el uso de la mordaza horizontal y vertical
- Montaje fácil y rápido del accesorio sobre la máquina por medio de 2 puntos de montaje rápido
- Diseño exclusivo y patentado



CUTTING CAPACITY / CAPACIDAD DE CORTE

		Cut at 0°/Corte a 0°	Cut at 45°/Corte a 45°
XXX EVO XXX EVO ALU	Ø 305	200 mm × h 10 mm	130 mm × h 10 mm
305 PRO	Ø 305	205 mm × h 10 mm	140 mm × h 10 mm
911 EVO	Ø 305	210 mm × h 10 mm	142 mm × h 10 mm
999 EVO	Ø 305	210 mm × h 10 mm	142 mm × h 10 mm



L max 210 mm
H max 10 mm

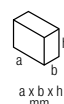

500x230x90



3

305 S

ART.	CODE / CÓDIGO
305 S	8.43.80.22

TECHNICAL FEATURES

- Very sturdy and robust structure: great reliability and cutting precision
- Movement of the turning table entirely on bearings
- Head return system protected with anti-fall spring
- Sheet metal frontal blade protection
- Silent 1400W induction motor
- Cutting angle adjustable from 0° to 45° right and left

STANDARD EQUIPMENT

- Blade with Widia inserts
- Adjustable bar stop-rod for mass-produced cuts
- Key set
- Supplementary protection and wood pusher

CARACTERÍSTICAS TÉCNICAS

- Estructura muy sólida y rígida: gran fiabilidad y precisión de corte
- Movimientos de la mesa giratoria enteramente sobre cojinetes
- Sistema de retorno de la cabeza con muelle anti-caída
- Cáster de corte frontal en chapa laminada
- Motor de inducción silencioso 1400 Watt
- Ángulo de corte regulable de 0° a 45° izquierda Y derecha

EQUIPAMIENTO DE SERIE

- Disco con inserciones en Widia
- Varilla de sujeción de la barra para realizar cortes en serie
- Llaves en dotación
- Protección adicional y accesorio para empujar la madera



- Great precision and cutting capacity (170 mm x 78 mm)
- Gran precisión y capacidad de corte (170 mm x 78 mm)

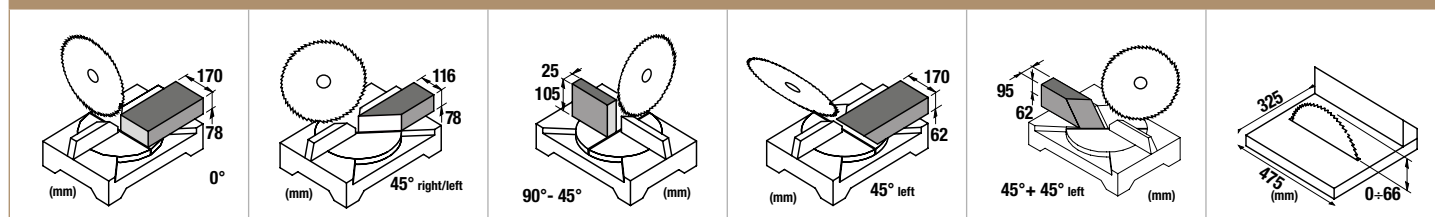

- Upper working table 475 mm x 325 mm with 66 mm cutting height
- Mesa superior 475 mm x 325 mm con capacidad de corte 66 mm

CUTTING CAPACITY / CAPACIDAD DE CORTE

1400 WATT



3000



D305 -d30



640x640x510



29



78 mm



170 mm

□ 230 Volt - Hz 50 single-phase motor / Motor monofásico 230 Volt - Hz 50

280 S

ART.	CODE / CÓDIGO
280 S	8.42.80.21

TECHNICAL FEATURES

- The only mitresaw in the world with Ø 280 mm blade
- Movement of the turning table entirely on bearings
- Great cutting performances 150 x 70 mm
- Silent 1300W induction motor
- Ideal handle for ground working
- 2-positions upper work table cutting guide
- Double mitre cut 45°+45° left

STANDARD EQUIPMENT

- Blade with Widia inserts for the maximum material penetration
- Adjustable bar stop-rod for mass-produced cuts
- Key set
- Supplementary protection and wood pusher

CARACTERÍSTICAS TÉCNICAS

- La única tronzadora en el mundo con disco Ø 280 mm
- Movimientos de la mesa giratoria enteramente sobre cojinetes
- Grandes prestaciones de corte 150 x 70 mm
- Motor de inducción silencioso 1300 W
- Empuñadura ideal para trabajos en tierra
- Guía corte mesa superior de dos posiciones
- Corte combinado 45°+45° izquierda

EQUIPAMIENTO DE SERIE

- Disco con inserciones en Widia para la máxima penetración en el material
- Varilla de sujeción de la barra para realizar cortes en serie
- Llaves en dotación
- Protección adicional y accesorio para empujar la madera



- Cutting angle adjustable from 0° to 45° right and left
- Ángulo de corte regulable de 0° a 45° izquierda y derecha



- Sturdy and robust structure for a great cutting precision
- Estructura sólida y rígida para una gran precisión de corte

CUTTING CAPACITY / CAPACIDAD DE CORTE

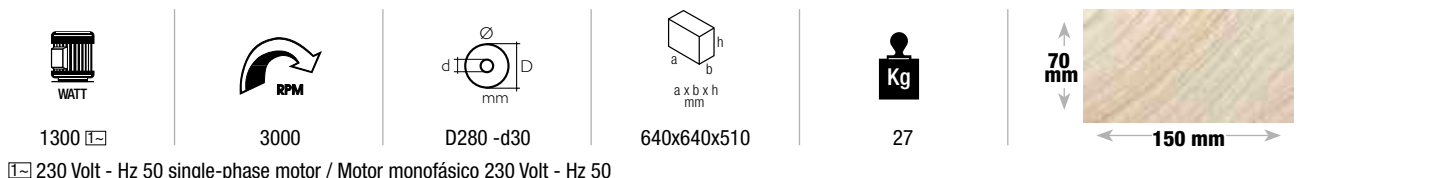
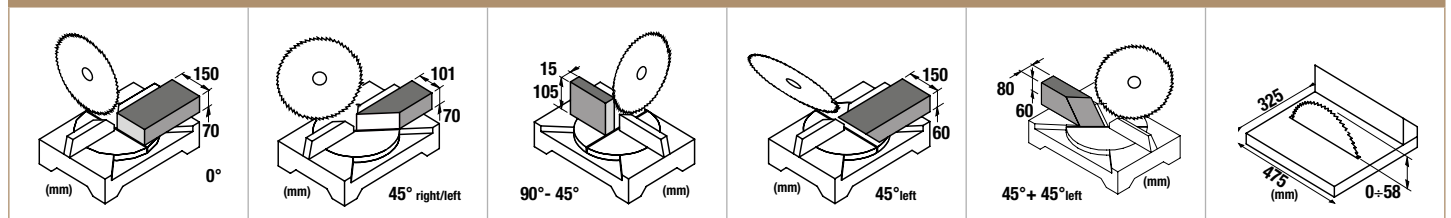

230 Volt - Hz 50 single-phase motor / Motor monofásico 230 Volt - Hz 50

732 / 733

ART.	CODE / CÓDIGO
732	8.42.00.28

732



TECHNICAL FEATURES

- Die cast aluminium body
- Cutting capacity 162 mm!
- Powerful universal motor 1550 Watt
- Double mitre cut 45°+ 45° left
- Upper table 360x462 mm

STANDARD EQUIPMENT

- Blade with Widia inserts
- Adjustable bar stop-rod for massproduced cuts
- Supplementary protection and wood pusher and key set
- Vertical clamp

CARACTERÍSTICAS TÉCNICAS

- Estructura de aluminio fundido a presión
- Capacidad de corte 162 mm!
- Potente motor universal 1550 W
- Corte combinado 45° + 45° izquierda
- Mesa superior provista de guía, con altura regulable (360x462 mm)

EQUIPAMIENTO DE SERIE

- Disco con inserciones de Widia
- Varilla de sujeción de la barra
- Protección adicional y accesorio para empujar la madera y llaves
- Mordaza vertical

1550 W	4200 RPM	D254 -d30	530x535x390 mm	14,5 Kg	H max 78 mm	L max 162 mm

⚡ 230 Volt - Hz 50 single-phase motor / Motor monofásico 230 Volt - Hz 50

CUTTING CAPACITY / CAPACIDAD DE CORTE

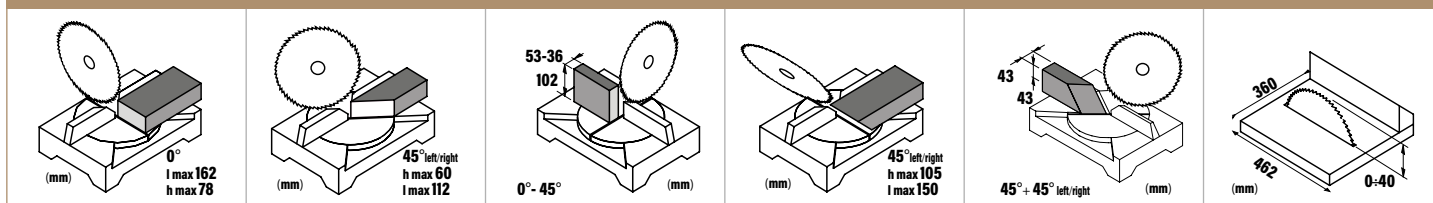

ART.	CODE / CÓDIGO
733	8.42.00.29

733



TECHNICAL FEATURES

- Die cast aluminium body
- Cutting capacity 162 mm!
- Silent and powerful induction motor 1300 W
- Upper table 360x462 mm!!
- Adjustable cutting angle from 0° to 47° right and left

STANDARD EQUIPMENT

- Blade with Widia inserts
- Key set
- Adjustable bar stop-rod for massproduced cuts
- Supplementary protection and wood pusher
- Vertical clamp

CARACTERÍSTICAS TÉCNICAS

- Estructura de aluminio fundido a presión
- Capacidad de corte 162 mm!
- Motor de inducción 1300 W silencioso y potente
- Mesa superior provista de guía, con altura regulable (360x462 mm)
- Ángulo de corte regulable de 0° a 47° derecha e izquierda

EQUIPAMIENTO DE SERIE

- Disco con inserciones de Widia para la máxima penetración en el material
- Llaves en dotación
- Varilla de sujeción de la barra
- Protección adicional y accesorio para empujar la madera
- Mordaza vertical

1300 W	2850 RPM	D254 -d30	530x535x390 mm	17,5 Kg	H max 75 mm	L max 162 mm

⚡ 230 Volt - Hz 50 single-phase motor / Motor monofásico 230 Volt - Hz 50

CUTTING CAPACITY / CAPACIDAD DE CORTE

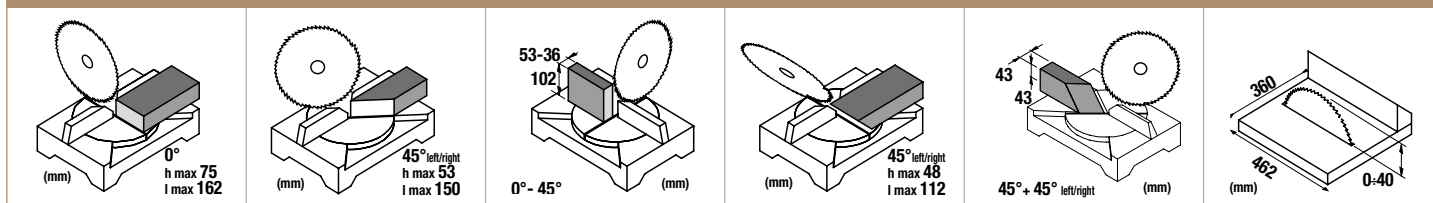

XXX EVO ALU

ART.	CODE / CÓDIGO
XXX EVO ALU	8.43.60.46

TECHNICAL FEATURES

- New T.P.S. (Three Position System) handle (PATENTED)
- Movements on bearings of the turning table, head and joint
- Powerful 1500 Watt silent induction motor
- Piece support with sliding kit (INCLUDED)

STANDARD EQUIPMENT

- Chrome coated blade with Widia inserts and noise dampening-slot
- Vertical clamp
- Adjustable bar stop-rod for mass-produced cuts
- Sliding kit

CARACTERÍSTICAS TÉCNICAS

- Nueva empuñadura TPS (Three Position System) (PATENTADO)
- Movimientos sobre cojinetes de la mesa giratoria, cabeza y articulación
- Motor de inducción silencioso y potente 1500 Watt
- Apoyo de la pieza con kit de deslize incluido

EQUIPAMIENTO DE SERIE

- Hoja con inserciones en Widia cromada y con hendiduras silenciadoras
- Mordaza vertical
- Varilla de sujeción de la barra para realizar cortes en serie
- Kit de deslizamiento



- Vertical clamp included
- Mordaza vertical incluida



- Special Z84 blade for alu
- Disco Especial Z84 para aluminio

PATENTED

T.P.S. THREE POSITIONS SYSTEM



CUTTING CAPACITY / CAPACIDAD DE CORTE

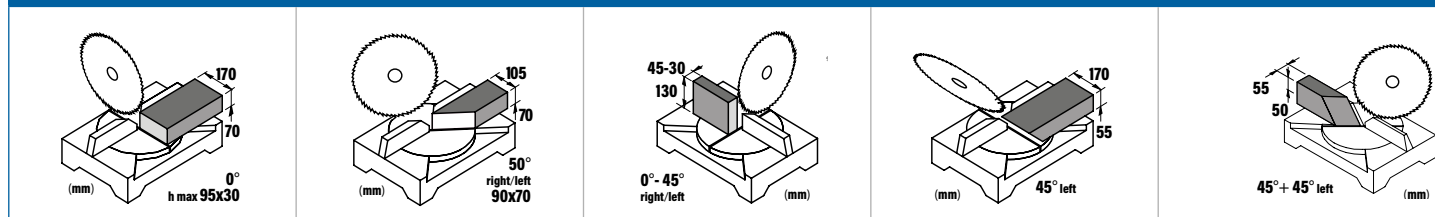

1500 W



2850



D305 -d30



630x630x500



21,5





70 mm

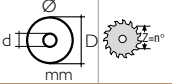

170 mm

⚡ 230 Volt - Hz 50 single-phase motor / Motor monofásico 230 Volt - Hz 50

CODE CÓDIGO			USES USOS	FOR ART. PARA ART.
BLADES FOR WOOD AND PLASTIC MATERIALS / DISCOS PARA MADERA Y MATERIAS PLÁSTICAS				
3.27.85.26	250x30	24	2,5	Shredding and ripping of: soft woods, hard woods, solid woods Troceado y corte a lo largo de la veta de: maderas blandas, duras y macizas
3.27.85.28	250x30	40*	2,5	Shredding and ripping of: soft woods, hard woods, solid woods Troceado y corte a lo largo de la veta de: maderas blandas, duras y macizas
3.27.85.07	250x30	60	2,5	Ripping and crosscutting of: soft and hard woods, solid and exotic woods, chipboard and stratified panels. Corte a lo largo y a través de la veta de: maderas blandas, exóticas, aglomerada y paneles estratificados.
3.27.85.08	250x30	80	3,2	Ripping and crosscutting of: soft and hard woods, solid and exotic woods, chipboard and stratified panels. Crosscutting of: chipboard, thermoplastic, MDF, laminated on one side. Trimming of: wooden frames, skirting board, excellent quality woods. Corte a lo largo y a través de la veta de: maderas blandas, duras, macizas, exóticas, aglomerada y paneles estratificados. Corte a través de la veta de: madera aglomerada, termoplásticos, MDF, laminados sobre una sola cara. Acabado de: marcos, listones y maderas preciosas.
3.27.85.39	254x30	24*	2,5	Shredding and ripping of: soft woods, hard woods, solid woods Troceado y corte a lo largo de la veta de: maderas blandas, duras y macizas
3.27.85.40	254x30	40*	2,5	Shredding and ripping of: soft woods, hard woods, solid woods Troceado y corte a lo largo de la veta de: maderas blandas, duras y macizas
3.27.85.29	300x30	48	2,5	Shredding and ripping of: soft woods, hard woods, solid woods. Troceado y corte a lo largo de la veta de: maderas blandas, duras y macizas
3.27.85.13	300x30	72	3,2	Ripping and crosscutting of: soft and hard woods, solid and exotic woods, chipboard and stratified panels. Corte a lo largo y a través de la veta de: maderas blandas, duras, macizas, exóticas, aglomerada y paneles estratificados.
3.27.85.14	300x30	96	3,2	Ripping and crosscutting of: soft and hard woods, solid and exotic woods, chipboard and stratified panels. Crosscutting of: chipboard, thermoplastic, MDF, laminated on one side. Trimming of: wooden frames, skirting board, excellent quality woods. Corte a lo largo y a través de la veta de: maderas blandas, duras, macizas, exóticas, aglomerada y paneles estratificados. Corte a través de la veta de: madera aglomerada, termoplásticos, MDF, laminados sobre una sola cara. Acabado de: marcos, listones y maderas preciosas.
3.27.85.31	305x30	48*	2,5	Shredding and ripping of: soft woods, hard woods, solid woods Troceado y corte a lo largo de la veta de: maderas blandas, duras y macizas
3.27.99.51	305x30	72	3,0	Ripping and crosscutting of: soft and hard woods, solid and exotic woods, chipboard and stratified panels. Corte a lo largo y a través de la veta de: maderas blandas, duras, macizas, exóticas, aglomerada y paneles estratificados.
3.27.99.52	305x30	96	3,2	Ripping and crosscutting of: soft and hard woods, solid and exotic woods, chipboard and stratified panels. Crosscutting of: chipboard, thermoplastic, MDF, laminated on one side. Trimming of: wooden frames, skirting board, excellent quality woods. Corte a lo largo y a través de la veta de: maderas blandas, duras, macizas, exóticas, aglomerada y paneles estratificados. Corte a través de la veta de: madera aglomerada, termoplásticos, MDF, laminados sobre una sola cara. Acabado de: marcos, listones y maderas preciosas.

*Standard fitting - En dotación estándar

BLADES FOR ALUMINIUM / DISCOS PARA ALUMINIO				
3.27.85.09	250x30	80	3,2	Cutting of: aluminium sections and extrusions Tronzado de: elementos perfilados y extrusionados de aluminio y metales no ferrosos.
3.27.85.41	254x30	80	3,2	Cutting of: aluminium sections and extrusions Tronzado de: elementos perfilados y extrusionados de aluminio y metales no ferrosos.
3.29.00.09	280x30	64	3,0	Cutting of: aluminium sections and extrusions Tronzado de: elementos perfilados y extrusionados de aluminio y metales no ferrosos.
3.27.85.21	300x30	84	3,0	Cutting of: aluminium sections and extrusions Tronzado de: elementos perfilados y extrusionados de aluminio y metales no ferrosos.
3.27.85.15	300x30	96	3,0	Cutting of: aluminium sections and extrusions Tronzado de: elementos perfilados y extrusionados de aluminio y metales no ferrosos.
3.27.99.53	305x30	84*	3,0	Cutting of: aluminium sections and extrusions Tronzado de: elementos perfilados y extrusionados de aluminio y metales no ferrosos.
3.27.99.54	305x30	96	3,0	Cutting of: aluminium sections and extrusions Tronzado de: elementos perfilados y extrusionados de aluminio y metales no ferrosos.

*Standard fitting - En dotación estándar

IB 500

ART.	CODE / CÓDIGO
IB 500	8.62.01.26

TECHNICAL FEATURES

- Solid metal sheet frame, adjustable support feet for the maximum stability
- Hot air flow - 2 speeds: 18-30 m³/h
- Adjustable heating temperature from 350°C to 500°C
- Folding outrigger support

EDGE BANDING SYSTEM

- Designed for hot-melt adhesives edge banding materials higher no more than 48 mm
- Ideal for finishing linear and moulded panels

•CARACTERÍSTICAS TÉCNICAS

- Estructura robusta, con patas de nivelación ajustables para un trabajo en máxima estabilidad
- Flujo de calor 2 velocidades: 18-30 m³/h
- Temperatura de calentamiento ajustable desde 350°C hasta 500°C
- Soporte para el rodillo de sujeción plegable

ENCOLADORA DE CANTOS

- Para el pegado por calor de rollos de altura máxima 48 mm
- Ideal para el acabado de paneles lineales y perfilados



VIDEO



2000



18-30



Ø max 48 mm



350°- 500°



12

a x b x h
mm
730x420x255

STANDY



ART.	CODE / CÓDIGO
390	7.13.36.87

TECHNICAL FEATURES

- Sturdy stoved painted steel structure
 - Pre-arranged to be fixed on the floor
 - Maximum charge 150 kg
- ### CARACTERÍSTICAS TÉCNICAS
- Robusta estructura de acero pintada en caliente
 - Está adaptada para ser fijada al piso
 - Max posibilidad de carga: 150 kg

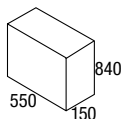

WOOD SUPPORT FOR FIXING MITERSAWS TO THE COLUMN (INCLUDED)

BASE DE FIJACIÓN DE MADERA INCLUIDA



UNIVERSAL COLUMN FOR MITERSAWS BASE EXPOSITORA UNIVERSAL PARA TRONZADORAS DE MADERA

ART.	CODE CÓDIGO	FOR ART. PARA ART.	Kg
390	7.13.36.87	All the mitersaws Todas las tronadoras	15

JOBBY

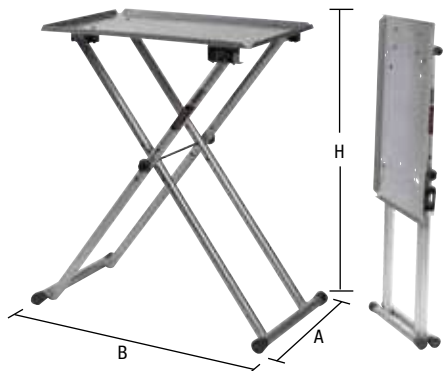

ART.	CODE / CÓDIGO
300 PLUS	7.13.36.48

TECHNICAL FEATURES

- Foldable for easy handling
- Sturdy steel section structure
- Height adjustable in three positions

CARACTERÍSTICAS TÉCNICAS

- Plegable para un fácil transporte
- Estructura de perfil de acero robusto
- Altura regulable en tres posiciones



Safety system against accidental locking
Sistema de seguridad contra un cierre accidental

FOLDING TABLE "JOBBY" / BANCO PLEGABLE "JOBBY"

SIZE axbxh / DIMENSIONES axbxh	FOR ART. / PARA ART.
650x420x740/820/870	All the mitersaws Todas las tronadoras

MULTY



ART.	CODE / CÓDIGO
360	7.13.36.47

TECHNICAL FEATURES

- Sturdy solid aluminium structure
- Universal couple of brackets for the bandsaw and mitersaw fixing
- Possibility to electrically connect three tools
- Integrated handle for an easy transport
- Side supports extensible, height and width adjustable
- Maximum charge: 120 kg

CARACTERÍSTICAS TÉCNICAS

- Robusta estructura en perfilado de aluminio
- Par de abrazaderas universales para fijar tronadoras y SIERRA de cinta
- Posibilidad de conectar eléctricamente hasta 3 aparatos
- Empuñadura integrada para un fácil transporte
- Apoyos laterales extensibles, regulables en alto y ancho
- Max posibilidad de carga: 120 kg

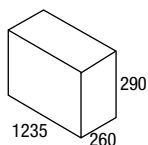

FOLDING TABLE "MULTY" / BANCO PLEGABLE "MULTY"

FOR ART. PARA ART.	Kg
All the mitersaws / Todas las tronadoras	20



Kit of brackets for quick fixing.
Kit de abrazaderas para fijado rápido



Additional kit on demand
Kit adicional bajo pedido

CODE / CÓDIGO
7.13.06.58



SLIDING KIT / KIT DE DESLIZE

CODE / CÓDIGO	FOR ART. / PARA ART.
7.07.50.36	911 EVO - 999 EVO XXX EVO - XXX EVO ALU - 305 PRO



CLAMPS / MORDAZAS UNIVERSALES

CODE / CÓDIGO	FOR ART. / PARA ART.
7.13.05.57 - Frontal/Horizontal	305S - 280S - 732 - 733
7.13.07.01 - Vertical/Vertical	XXX EVO -305 PRO - 911 - 999 EVO XXX EVO ALU - 846 - 846 ALU - 300 SPECIAL - 842
7.13.06.07 - Frontal/Horizontal	XXX EVO - XXX EVO ALU
7.13.06.41 - Frontal/Horizontal	305 PRO - 911 - 999 - 846 - 846 ALU 300 SPECIAL - 842

Lateral extension of the upper table

- Lateral extension in aluminium extrusion
- Accurate and steady fixing
- Increases the upper table dimensions from 305mm x 485 mm to 455mm x 485mm

Extensión lateral de la mesa superiores

- Extensión lateral en extrusion de aluminio
- Fijación precisa y estable
- Aumenta el tamaño de la mesa superior de 305mm x 485 mm asta 455mm x 485mm

LATERAL EXTENSION / EXTENSIÓN LATERAL

CODE / CÓDIGO	FOR ART. / PARA ART.
7.07.50.77	911 EVO - 999 EVO - XXX EVO - 305 PRO

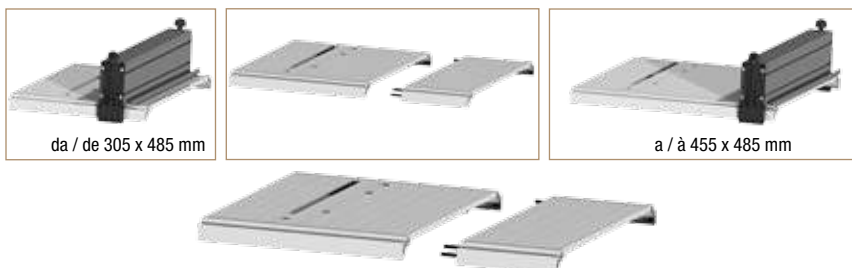

SINGLE-ROLLER SUPPORT / SOPORTE MONO-RODILLO

ART.	CODE / CÓDIGO	SIZE / DIMENSIONES AxBxH (mm)	WEIGHT / PESO
301	7.13.37.16	520x400x680÷1140	6,5 kg

TECHNICAL FEATURES

- Zinc-plated steel roller Ø 57 mm
- Sturdy steel structure
- Base equipped with leveling feet
- Support height adjustment
- Maximum charge: 30 kg

CARACTERÍSTICAS TÉCNICAS

- Rodillo de acero galvanizado Ø 57 mm
- Robusta estructura de acero, hierro fundido
- Base provista de pies de nivelación
- Regulación de la altura de apoyo
- Max posibilidad de carga: 30 kg

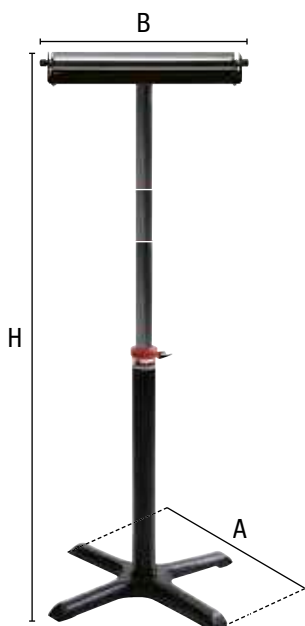

GRADUATED GONIOMETER | GONIÓMETRO GRADUADO

CODE / CÓDIGO	ANGLE REG. / REG. ÁNGULO	FOR ART. / PARA ART.
5.13.07.68	0° - 60° left-right	GOLD-XXX2-911-999-846-300 SPECIAL-842



DUST COLLECTION BAG / BOLSA DE RECOGIDA DE VIRUTAS

CODE / CÓDIGO	FOR ART. / PARA ART.
7.07.50.32	All the mitresaws / Todas las tronzadoras

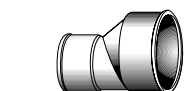

MITRESAW DUST COLLECTOR ADAPTER / ADAPTADOR ASPIRACION PARA TRONZADORAS

CODE / CÓDIGO	Ø REDUCTION / Ø REDUCCIÓN	Ø MITRESAW COUPLING / Ø ACOPLER TRONZADORA	FOR ART. / PARA ART.
5.06.10.44	100 mm	40 mm	305 PRO / 999 EVO / 911 EVO XXX EVO / XXX EVO ALU

DISPLAYS



DCS DISPLAY

CODE / CÓDIGO 0.00.08.52

Weight / Peso: 4,7 kg

Cardboard display for DCS NG110 bandsaw

Panel de cartón
para sierra de cinta DCS NG110

DCS NG110 bandsaw not included
DCS NG110 Sierra de cinta no incluidas

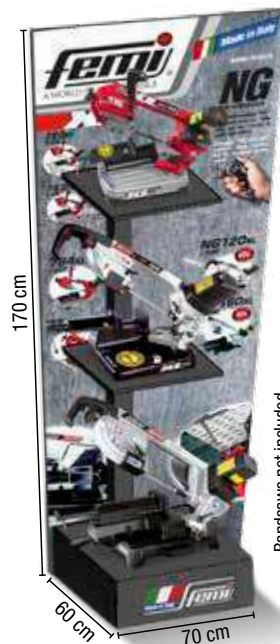

METAL LINE LÍNEA METAL

Metal display

Expositor metal

CODE / CÓDIGO 7.13.36.72

Weight / Peso: 30 kg

Maximum charge of each shelf: 30 kg.

Máxima posibilidad de carga de los estantes: 30 kg

Maximum charge of bottom base: 35 kg.

Máxima posibilidad de carga de la base: 35 kg

Cardboard panel

Panel de cartón

CODE / CÓDIGO 7.13.36.74

Bandsaws not included
Sierras de cinta no incluidas

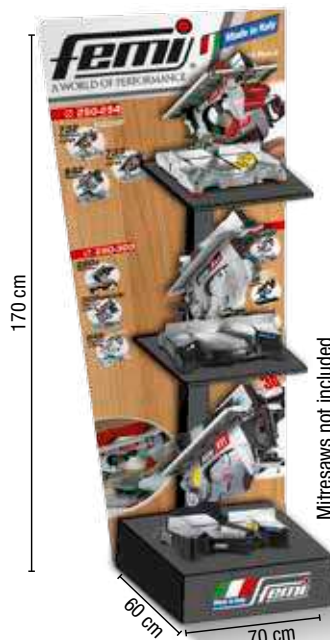

WOOD LINE LÍNEA MADERA

Metal display

Expositor metal

CODE / CÓDIGO 7.13.36.72

Weight / Peso: 30 kg

Maximum charge of each shelf: 30 kg.

Máxima posibilidad de carga de los estantes: 30 kg

Maximum charge of bottom base: 35 kg.

Máxima posibilidad de carga de la base: 35 kg

Cardboard panel

Panel de cartón

CODE / CÓDIGO 7.13.36.69

Mitresaws not included
Tronzadoras no incluidas

Cardboard display for 787 xl allroad Panel de cartón para 787 xl allroad

CODE / CÓDIGO 7.13.36.71

h. 180 cm

Weight / Peso: 1 kg



BENCH GRINDERS ESMERILADORAS

GRINDY

CODE / CÓDIGO 7.13.36.96

Display column for bench grinders Base expositora para esmeriladoras

Weight / Peso: 13 kg

Display unit column in bended steel metal
for displaying four bench grinders
Maximum charge for each shelf: 25 kg
(no limit charge for exposition on the base)

Base expositora de acero laminado y pensado para
la exhibición de cuatro esmeriles de banco
Maxima carga posible por cada piso: 25 kg (sin
límite de peso sobre la base)

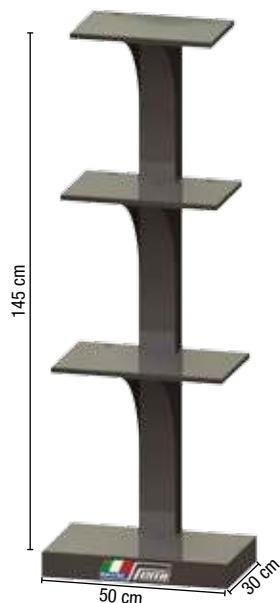

TRY ME! DEMO KIT

Cardboard display
Panel de cartón

CODE / CÓDIGO 0.00.07.86
Weight / Peso: 3,8 kg

**Bandsaw
not included**
Sierra de cinta
no incluida



190 cm



ART. 300
"JOBBOY"

Metal band saw spare blade
Hoja de cinta adicional



Metal piece for cutting tests
Pieza de metal para pruebas de corte





Flyers 16 x 23 cm
Folletos 16 x 23 cm





VIDEO

SYMBOLS / SIMBOLOGIA

-  Winding safety thermic protection
Protección térmica de seguridad de los bobinados

-  Single-phase electric motor 230 V - 50 Hz
Motor eléctrico monofásico 230 V - Hz 50

-  Three-phase electric motor at 1 or 2 speeds 400 V - 50 Hz
Motor eléctrico trifásico de 1 ó 2 velocidades 400 V - Hz 50

-  Blade tensioning device with light indicator and safety microswitch
Tensor de la hoja con indicador luminoso y microinterruptor deseguridad

-  CE certification: in compliance with EEC directives 2004/108 - 2006/42 - 2006/95
Certificación CE: conformidad con las directivas CEE 2004/108 - 2006/42 - 2006/95

-  Digital electronically controlled constant speed
Velocidad constante con control electrónico digital

-  Electronic speed adjustment
Regulación electrónica de la velocidad

-  Two speeds, electronically switched
Dos velocidades con conmutación electrónica

-  Two speeds, polar switched motor
Dos velocidades con conmutación polar del motor

-  Dust collection system
Sistema de aspiración del polvo

-  Double safety insulation
Doble aislamiento de seguridad

-  Grit: the higher number corresponds to the finer grain
Granulometría: a un número más alto corresponde un grano más fino

-  Ultra-low safety tension controls (24 Volt)
Mandos de seguridad de bajísima tensión (24 V)

FEMI SpA reserves the right to make without prior notice all changes which may be necessary to improve the product.

The general descriptions, pictures and drawings are not binding but only indicative

FEMI SpA se reserva el derecho a realizar cualquier cambio necesario para la mejora del producto, sin necesidad de previo aviso.

Las descripciones generales, imágenes o dibujos serán sólo indicativos y no vinculantes.



FEMI SpA

Via del Lavoro, 4
40023 Castel Guelfo (BO) · ITALY
Tel. +39 0542 487611
infocom@femi.it

www.femi.it



FEMI France Sarl

58, Avenue des Bruyères · 69150 Décines · FRANCE
Tel. +33 (0) 4 - 78702778
femifrance@femi.it

www.femi.it/fr